

# SPARE PARTS MANUAL

## CW6280E

Heavy Duty Centre Lathe (415V)  
800 x 4000mm - 130mm Bore



L587

# 目 录

## CONTENTS

01	床身及固定装置.....	1
	BED AND FIXING DEVISE	
02	床头箱.....	9
	HEADSTOCK	
04	刀架及床鞍.....	40
	SLIDE AND SADDLE	
05	刀架及床鞍.....	42
	SLIDE AND SADDLE	
06	溜板箱.....	47
	APRON	
07	进给箱.....	68
	GEARBOX	
08	挂轮.....	84
	CHANGE GEAR	
09	附件.....	86
	ACCESSORIES	
10B	中心架.....	88
	STEADY REST	
10C	跟刀架.....	90
	FOLLOW REST	
11	床身及固定装置.....	92
	BED AND FIXING DEVICE	
14	冷却系统.....	95
	COOLANT SYSTEM	
15	电机装置.....	98
	MOTOR	
20	电气箱.....	101
	ELECTRIC CABINET	
72	管路.....	103
	PIPE LINE	
74	三爪卡盘防护罩.....	107
	3-JAW CHUCK GUARD	
76	前挡屑装置.....	109
	FRONT CHIP PROTECTION DEVICE	
95	纵向挡铁.....	111
	LOGNITUDINAL BED STOP	

CW6163C

Purchase Parts



图01-01 床身及固定装置  
FIG01-01 BED AND FIXING DEVICE

部别 01  
GROUP  
插图号 01-01  
FIG No.

## 床身及固定装置 BED AND FIXING DEVICE

图上序号 POSITION No.	件号 PART No.	名称 DESCRIPTION	数量 Q'TY	附注 REMARKS
1	CW6163C-01-011A/1000	床 身 BED	1	1000
1	CW6163C-01-011A/1500	床 身 BED	1	1500
2	CW6163C-01-012/1000	油盘焊接件 OIL TRAY	1	1000
2	CW6163C-01-012/1500	油盘焊接件 OIL TRAY	1	1500
3	CW6163C-01-013/1000	罩板焊接件 FRONT COVER PLATE	1	1000
3	CW6163C-01-013/1500	罩板焊接件 FRONT COVER PLATE	1	1500
4	CW6163C-01-015/1500	后 床 腿 BACK STAND PLINTH	1	1000,1500
5	CW6163C-01-014	前腿罩板 FORE PLINTH COVER PLATE	1	
6	CW6163C-01-016	厂 标 牌 MARK PLATE OF WORKS	1	
7	CW6163C-01-017	盖 COVER	1	
8	CW6163C-01-018	前 床 腿 FORE STAND PLINTH	1	CW6163C
9	CW6163C-01-019	风 窗 COVER	1	
10	CW6163C-01-021	盖 COVER	1	
11	CW6163C-01-022A	风 窗 COVER	1	
12	CW6163C-01-023	楔 铁 WEDGE BLOCK	6/6-8/8	
13	CW6163C-01-025/1000	标 牌 PLATE	1	1000
13	CW6163C-01-025/1500	标 牌 PLATE	1	1500
14	CW6163C-01-030	盖 COVER	1	
15	CW6163C-01-031	塑 料 垫 GASKET	1	
16	GB67	螺 钉 SCREW M6X12	4	
17	GB67	螺 钉 SCREW M8X16-Zn.D	8	
18	GB67	螺 钉 SCREW M8X20-Zn.D	10/10-14/14	
19	GB5782	螺 钉 SCREW M20X70	8/8-12/12	
20	GB799	地脚螺栓 FOUNDATION BOLT M24X400	6/6-8/8	
21	GB41	螺 母 NUT M24	6/6-8/8	
22	GB97.1	垫 圈 WASHER 20	8/8-12/12	
23	GB95	垫 圈 WASHER 24	6/6-8/8	
24	GB867	铆 钉 RIVET 2X6	8	

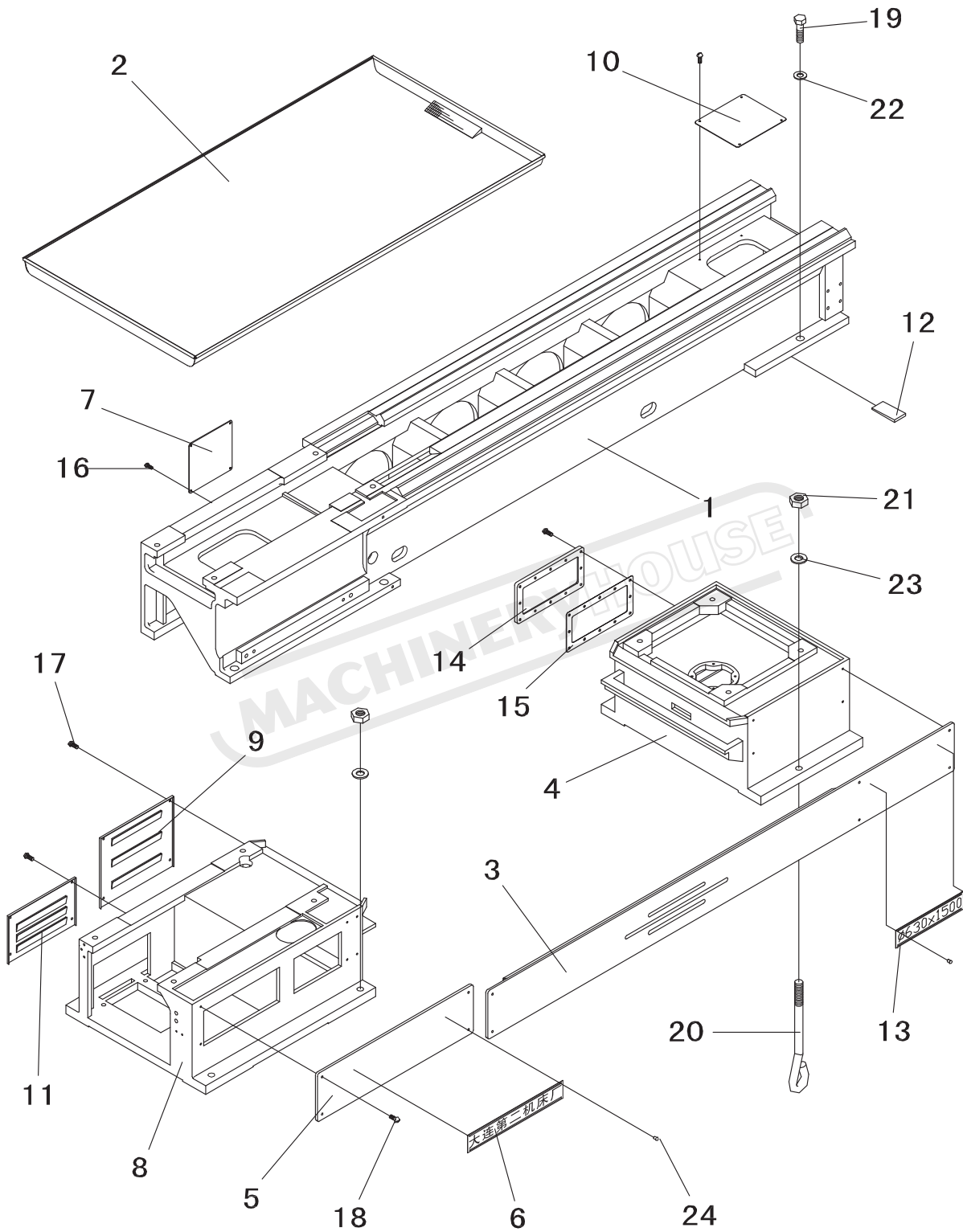
CW6163C

Purchase Parts



图01-02 床身及固定装置  
FIG01-02 BED AND FIXING DEVICE

## Purchase Parts

CW6163C

部别 01

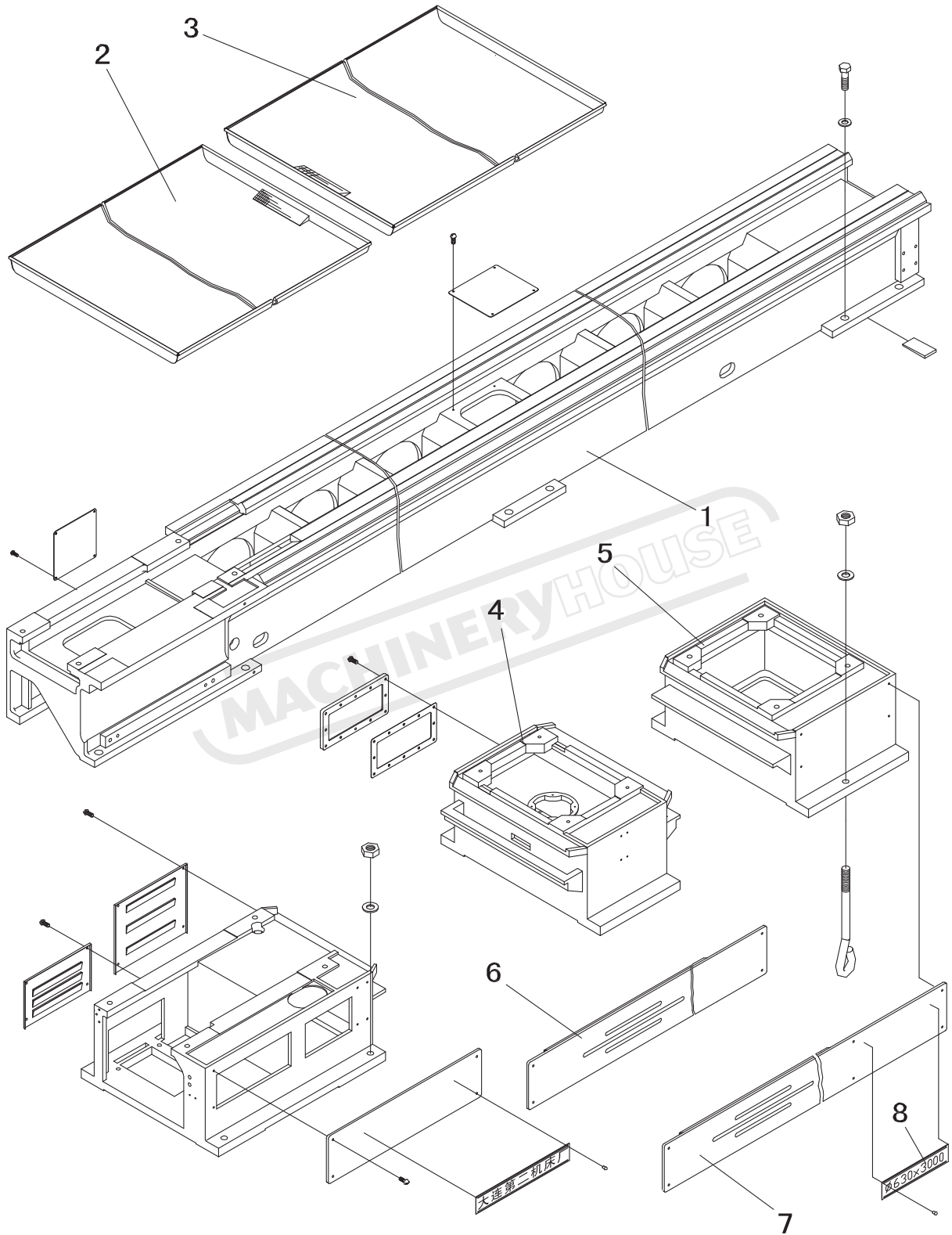
GROUP

插图号 01-02

FIG No.

# 床身及固定装置

## BED AND FIXING DEVICE

图上序号 POSITION No.	件号 PART No.	名称 DESCRIPTION	数量 Q'TY	附注 REMARKS
1	CW6163C-01-011A/2000	床 身 BED	1	2000
1	CW6163C-01-011A/3000	床 身 BED	1	3000
2	CW6163C-01-012/2000	前油盘焊接件 FORE OIL TRAY	1	2000
2	CW6163C-01-012/3000	前油盘焊接件 FORE OIL TRAY	1	3000
3	CW6163C-01-014/2000	后油盘焊接件 BACK OIL TRAY	1	2000
3	CW6163C-01-014/3000	后油盘焊接件 BACK OIL TRAY	1	3000
4	CW6163C-01-015/3000	中 床 腿 MIDDLE STAND	1	2000、3000
5	CW6163C-01-013/3000	后 床 腿 BACK STAND	1	2000、3000
6	CW6163C-01-013/2000	前 罩 板 FORE COVER PLATE	1	2000
6	CW6163C-01-026/3000	前 罩 板 FORE COVER PLATE	1	3000
7	CW6163C-01-015/2000	后 罩 板 BACK COVER PLATE	1	2000
7	CW6163C-01-027/3000	后 罩 板 BACK COVER PLATE	1	3000
8	CW6163C-01-016/2000	标 牌 PLATE	1	2000
8	CW6163C-01-025/3000	标 牌 PLATE	1	3000

CW6163C

Purchase Parts



图01-03 床身及固定装置  
FIG01-03 BED AND FIXING DEVICE

## Purchase Parts

CW6163C

部别 01  
GROUP  
插图号 01-03  
FIG No.

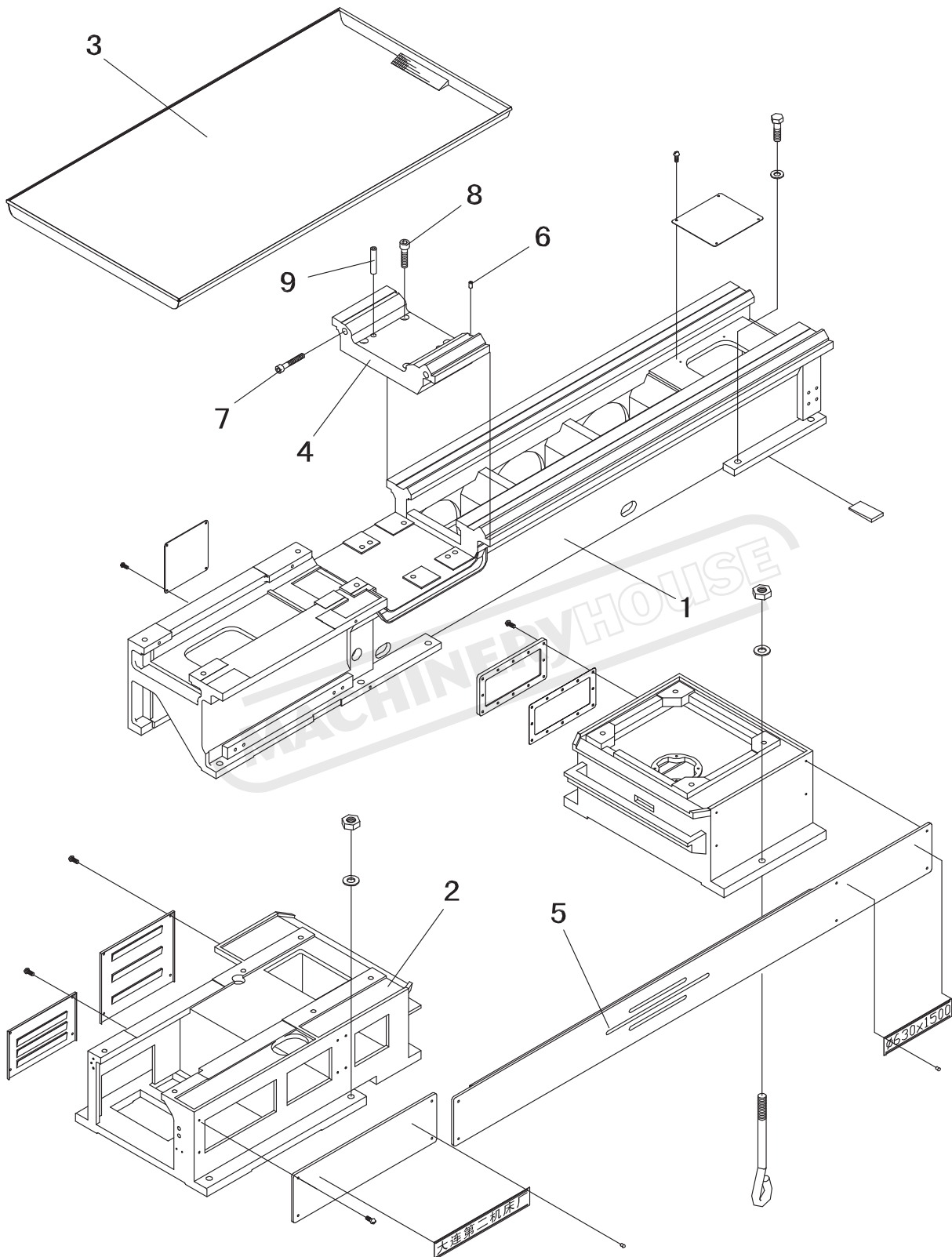
床身及固定装置  
BED AND FIXING DEVICE

图上序号 POSITION No.	件号 PART No.	名称 DESCRIPTION	数量 Q'TY	附注 REMARKS
1	CW6263C-01-011B/1000	床 身 BED	1	1000
1	CW6263C-01-011B/1500	床 身 BED	1	1500
2	CW6263C-01-018	前 床 腿 FORE STAND	1	
3	CW6263C-01-012/1000	油盘焊接件 OIL TRAY	1	1000
3	CW6263C-01-012/1500	油盘焊接件 OIL TRAY	1	1500
4	CW6263C-01-012A	马 鞍 GAP-PLATE	1	
5	CW6263C-01-013/1000	罩板焊接件 COVER PLATE	1	1000
5	CW6263C-01-013/1500	罩板焊接件 COVER PLATE	1	1500
6	CW6263C-01-013	圆 柱 销 CYLINDRICAL PIN	2	
7	GB70	螺 钉 M16X120 SCREW	2	
8	GB70	螺 钉 M20X80 SCREW	4	
9	GB118	圆 锥 销 TAPER PIN	2	



CW6163C

Purchase Parts



图01-04 床身及固定装置  
FIG01-04 BED AND FIXING DEVICE

Purchase Parts

CW6163C

部别 01

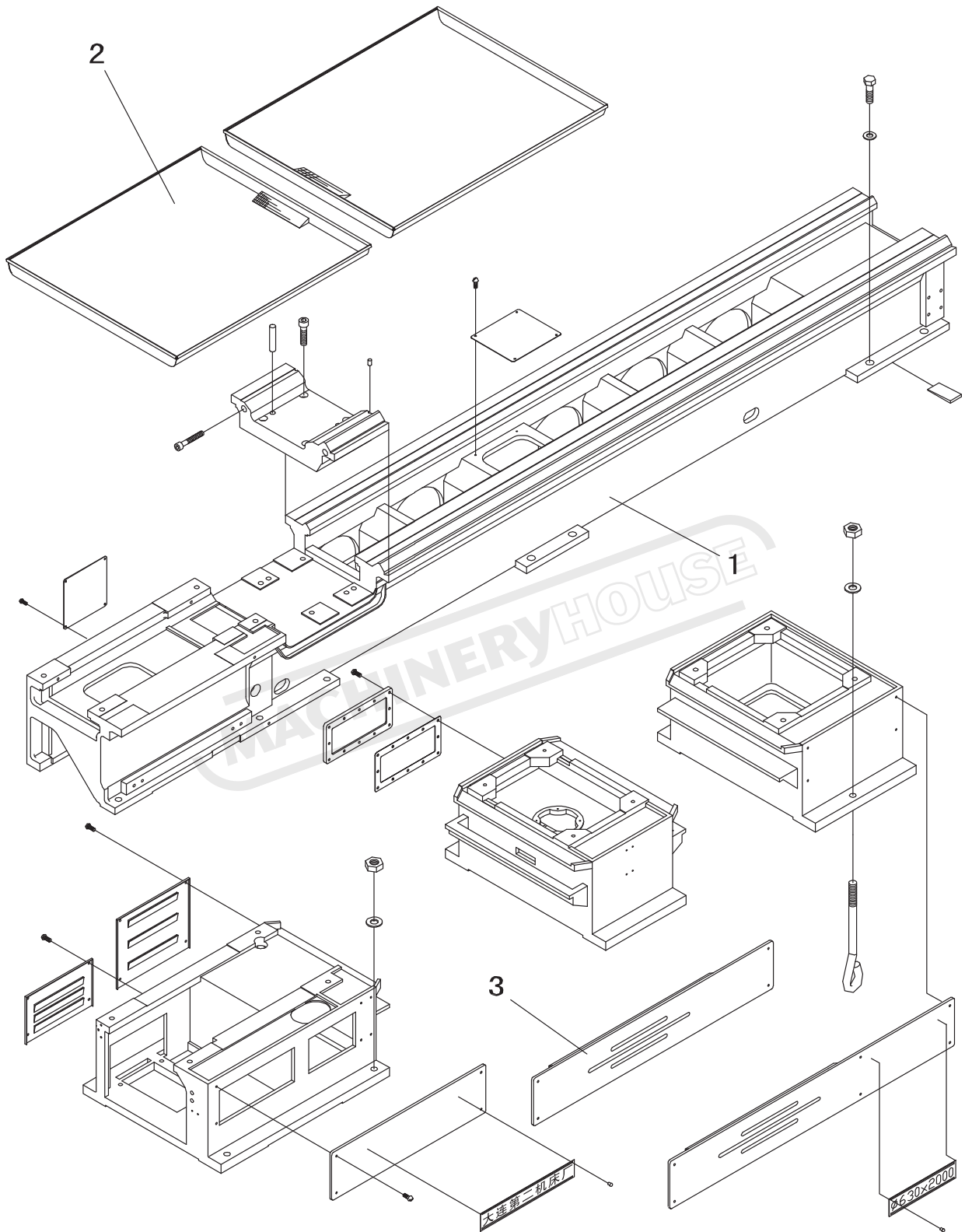
GROUP

插图号 01-04

FIG No.

## 床身及固定装置

## BED AND FIXING DEVICE

图上序号 POSITION No.	件号 PART No.	名称 DESCRIPTION	数量 Q'TY	附注 REMARKS
1	CW6263C-01-011B/2000	床身 BED	1	2000
1	CW6263C-01-011B/3000	床身 BED	1	3000
2	CW6263C-01-012/2000	前油盘 FORE OIL TRAY	1	2000
2	CW6263C-01-012/3000	前油盘 FORE OIL TRAY	1	3000
3	CW6263C-01-013/2000	前罩板 FORE COVER PLATE	1	2000
3	CW6263C-01-026/3000	前罩板 FORE COVER PLATE	1	3000

MACHINERYHOUSE

CW6163C

Purchase Parts



图02-01 床头箱  
FIG02-01 HEADSTOCK

## Purchase Parts

CW6163C

部别 02  
GROUP  
插图号 02-01  
FIG No.

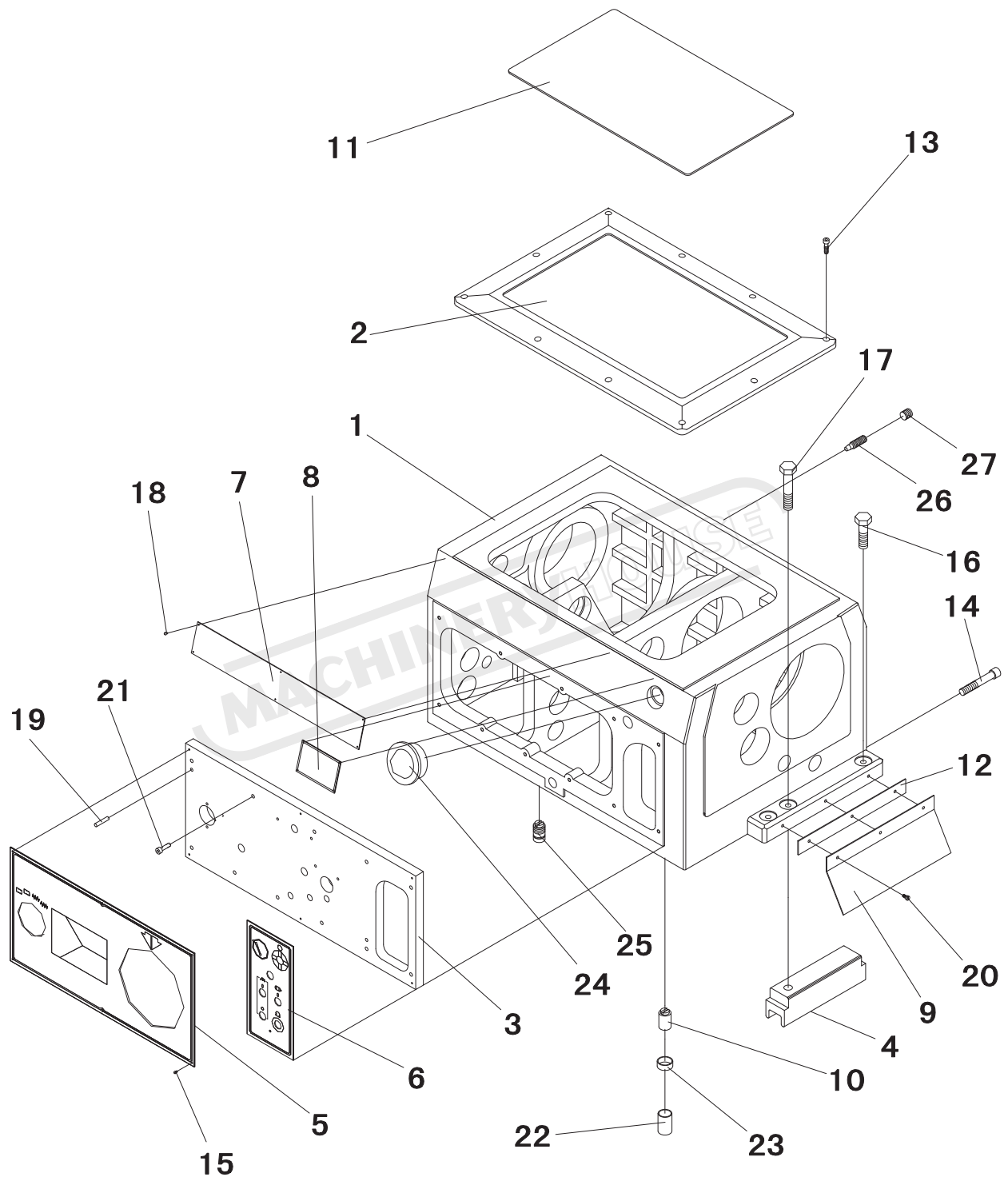
# 床头箱

## HEADSTOCK

图上序号 POSITION No.	件号 PART No.	名称 DESCRIPTION	数量 Q'TY	附注 REMARKS
1	CW6163C-02-011	床头箱体 HEADSTOCK CASTING	1	
2	CW6163C-02-012	箱 盖 HEADSTOCK COVER	1	
3	CW6163C-02-117	前 盖 FRONT COVER	1	
4	CW6163C-02-168	压 板 CLAMPING PAD	1	
5	CW6163C-02-185A	标 牌 PLATE	1	
6	CW6163C-02-187	标 牌 PLATE	1	
7	CW6163C-02-184	标 牌 MARK PLATE	1	
8	CW6163C-02-160	机床铭牌 MACHINE NAME PLATE	1	CW6163C
9	CW6163C-02-205	挡 板 PLATE	1	CW6163C
10	CW6163C-02-178A	回 油 管 OIL PIPE	1	
11	CW6163C-02-170	箱 盖 垫 GASKET	1	
12	CW6163C-02-206	垫 GASKET	1	
13	GB70	螺 钉 SCREW M8X30	10	
14	GB70	螺 钉 SCREW M16X100	2	
15	GB67	螺 钉 SCREW M3X6-Zn.D	6	
16	GB5782	螺 钉 SCREW M20X70	4	
17	GB5782	螺 钉 SCREW M20X75	1	
18	GB867	铆 钉 RIVET 2X6	10	
19	GB118	圆 柱 销 CYLINDRICAL PIN	2	
20	GB67	螺 钉 SCREW M6X12-Zn.D	3	
21	GB70	螺 钉 SCREW M8X30	11	
22	SG79	软 塑 管 PLASTIC SOFT PIPE $\phi$ 25X45	2	
23	D.J69-1	锁 紧 圈 DAMP RING 30	2	
24	GB1160.2	油 标 OIL WINDOW A-32	1	
25	CW6163-02-169	回 油 管 OIL PIPE	1	
26	CW6163-02-177	螺 钉 SCREW	1	
27	GB78	螺 钉 SCREW M20X20	1	

CW6163C

Purchase Parts



图02-02 床头箱  
FIG02-02 HEADSTOCK

## Purchase Parts

CW6163C

部别 02  
GROUP  
插图号 02-02  
FIG No.

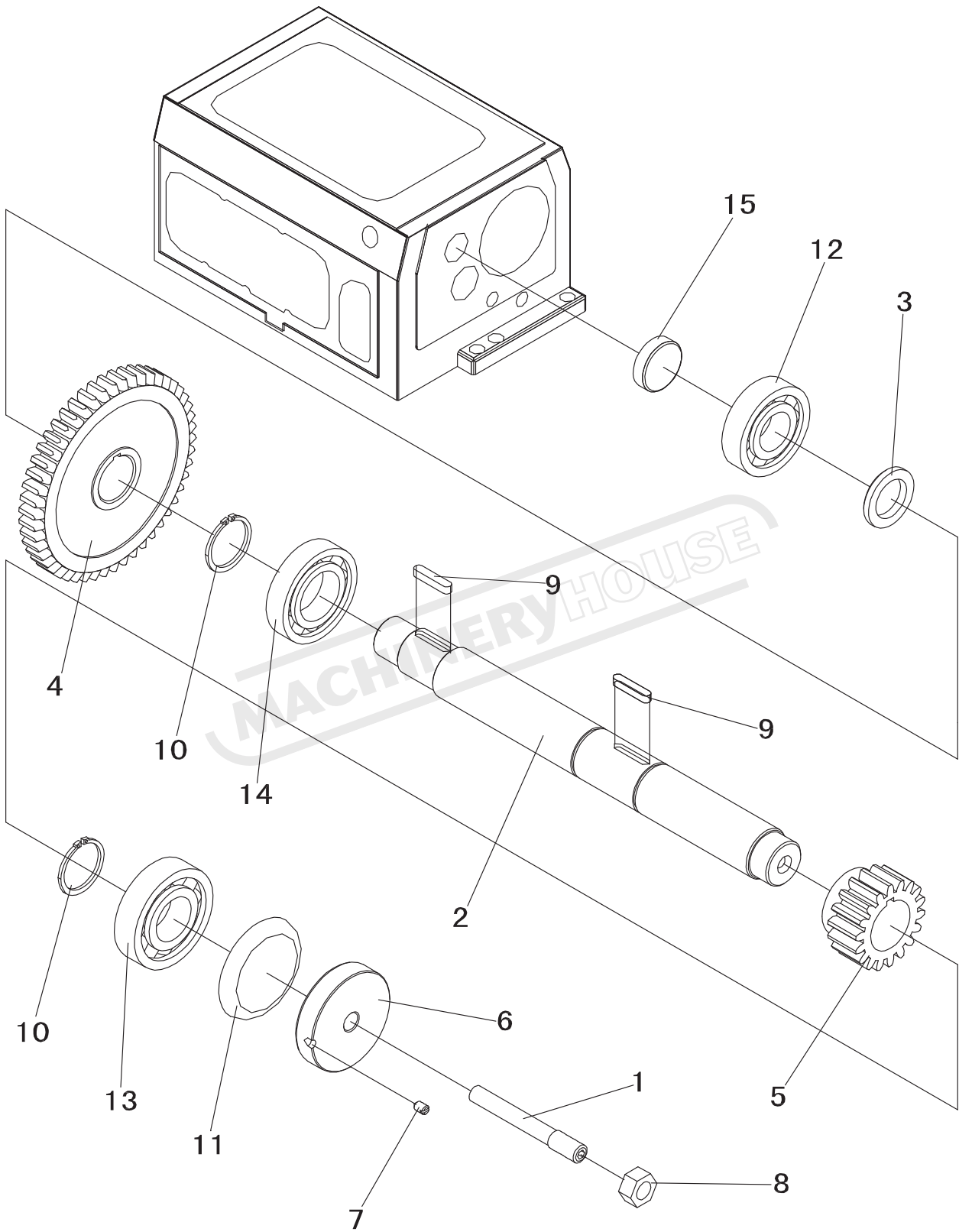
床头箱  
HEADSTOCK

图上序号 POSITION No.	件号 PART No.	名称 DESCRIPTION	数量 Q'TY	附注 REMARKS
1	CW6163C-02-032	调整螺钉 ADJUSTING SCREW	1	
2	CW6163C-02-066	IV轴 SHAFT	1	
3	CW6163C-02-067	垫 GASKET	1	
4	CW6163C-02-068	齿 轮 GEAR	1	
5	CW6163C-02-069	齿 轮 GEAR	1	
6	CW6163C-02-070	堵 PLUG	1	
7	GB71	螺 钉 SCREW M8X12	1	
8	GB6172	螺 母 NUT M16	1	
9	GB1096	平 键 FLAT KEY 8X7X40	2	
10	GB894.1	弹性挡圈 SNAP RING 45	2	
11	JB/GQ0464	顶 盘 WASHER 90	1	
12	GB276-64	轴 承 BEARING 307	1	
13	GB276-64	轴 承 BEARING 308	1	
14	GB276-64	轴 承 BEARING 209	1	
15	Q56-1	堵 塞 PLUG 45n6	1	

CW6163C

Purchase Parts



图02-03 床头箱  
FIG02-03 HEADSTOCK

## Purchase Parts

CW6163C

部别 02  
GROUP  
插图号 02-03  
FIG No.

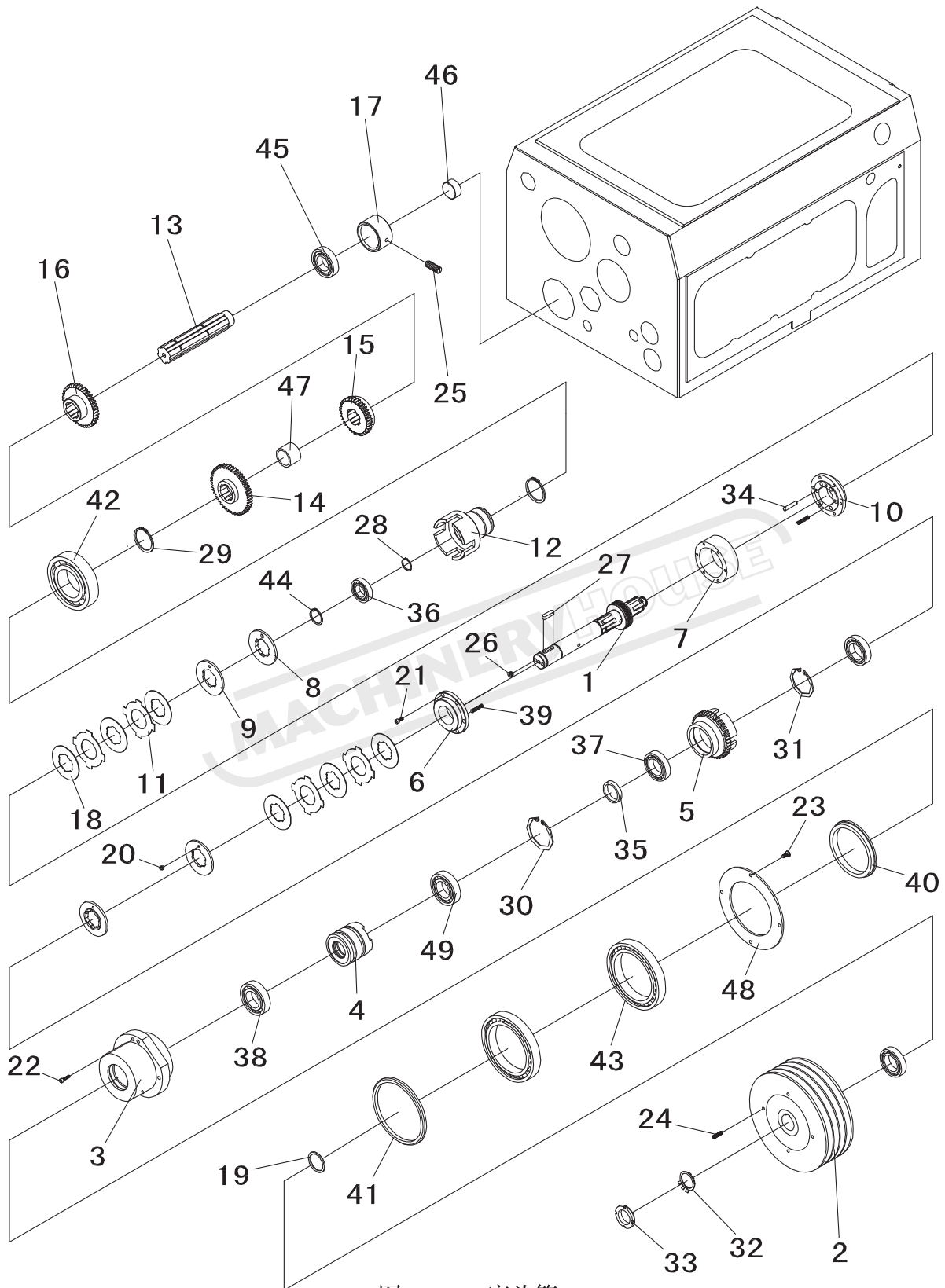
床头箱  
HEADSTOCK

图上序号 POSITION No.	件号 PART No.	名称 DESCRIPTION	数量 Q'TY	附注 REMARKS
1	CW6163C-02-013	皮带轮轴 PULLEY SHAFT	1	
2	CW6163C-02-014A	皮带轮 PULLEY	1	50Hz
2	CW6163C-02-014B	皮带轮 PULLEY	1	60Hz
3	CW6163C-02-015	法兰盘 FLANGE	1	
4	CW6163C-02-016	分油环 OIL DISTRIBUTION RING	1	
5	CW6163C-02-018	结合子齿轮 COUPLING GEAR	1	
6	CW6163C-02-023	法兰盘 FLANGE	1	
7	CW6163C-02-020	油缸 OIL CYLINDER	1	
8	CW6163C-02-021	挡环 RING	2	
9	CW6163C-02-022	挡环 RING	2	
10	CW6163C-02-019	法兰盘 FLANGE	1	
11	CW6163C-02-033	外摩擦片 OUTER FRICTION DISC	12	
12	CW6163C-02-025	结合子 COUPLING	1	
13	CW6163C-02-026	I轴 SHAFT	1	
14	CW6163C-02-027A	齿轮 GEAR	1	
15	CW6163C-02-028A	齿轮 GEAR	1	
16	CW6163C-02-029A	齿轮 GEAR	1	
17	CW6163C-02-030	定位堵 POSITIONING SPIGOT	1	
18	CW6163C-02-024	内摩擦片 INNER FRICTION DISC	14	
19	CW6163C-02-176	垫 GASKET	1	
20	CW6163C-02-189	销子 PIN	2	
21	GB70	螺钉 SCREW M6X16	12	
22	GB70	螺钉 SCREW M8X30	4	
23	GB68	螺钉 SCREW M8X16	4	
24	GB75	螺钉 SCREW M8X30	4	
25	GB71	螺钉 SCREW M10X12	1	
26	JB/GQ0318	油塞 OIL PLUG Z1/8"	4	
27	GB1096	平键 FLAT KEY 12X8X36	1	



CW6163C

Purchase Parts

部别 02  
GROUP  
插图号 02-03  
FIG No.

## 床头箱 HEADSTOCK

图上序号 POSITION No.	件号 PART No.	名称 DESCRIPTION	数量 Q'TY	附注 REMARKS
28	GB894.1	弹性挡圈 SNAP RING 30	1	
29	GB894.1	弹性挡圈 SNAP RING 70	2	
30	GB893.1	弹性挡圈 SNAP RING 85	1	
31	GB893.1	弹性挡圈 SNAP RING 75	1	
32	GB858	止退垫圈 STOP WANSHER 39	1	
33	GB812	圆螺母 ROUND NUT M39X1.5	1	
34	GB119	圆锥销 TAPER PIN A-8X40	1	
35	Q43-1	内隔套 SPACER 45X10	1	
36	GB276-64	轴承 BEARING D106	1	
37	GB276-64	轴承 BEARING D109	2	
38	GB292-64	轴承 BEARING 60209	1	
39	GB2089	弹簧 SPRING 1.6X8X35	12	
40	CW6163C-02-192	内隔套 SPACER	1	
41	CW6163C-02-194	垫 GASKET	1	
42	GB276-64	轴承 BEARING D214	1	
43	GB276-64	轴承 BEARING 100926	2	
44	GB894.1	弹性挡圈 SPRING SNAP RING 45	1	
45	GB276-64	轴承 BEARING D208	1	
46	Q56-1	堵塞 PLUG B45n6	1	
47	Q43-1	内隔套 SPACER 45X35	1	
48	CW6163C-02-193	盖 COVER	1	
49	GB276-64	轴承 BEARING D209	1	

Purchase Parts

CW6163C



图02-04 床头箱  
FIG02-04 HEADSTOCK

CW6163C

Purchase Parts

部别 02  
GROUP  
插图号 02-04  
FIG No.

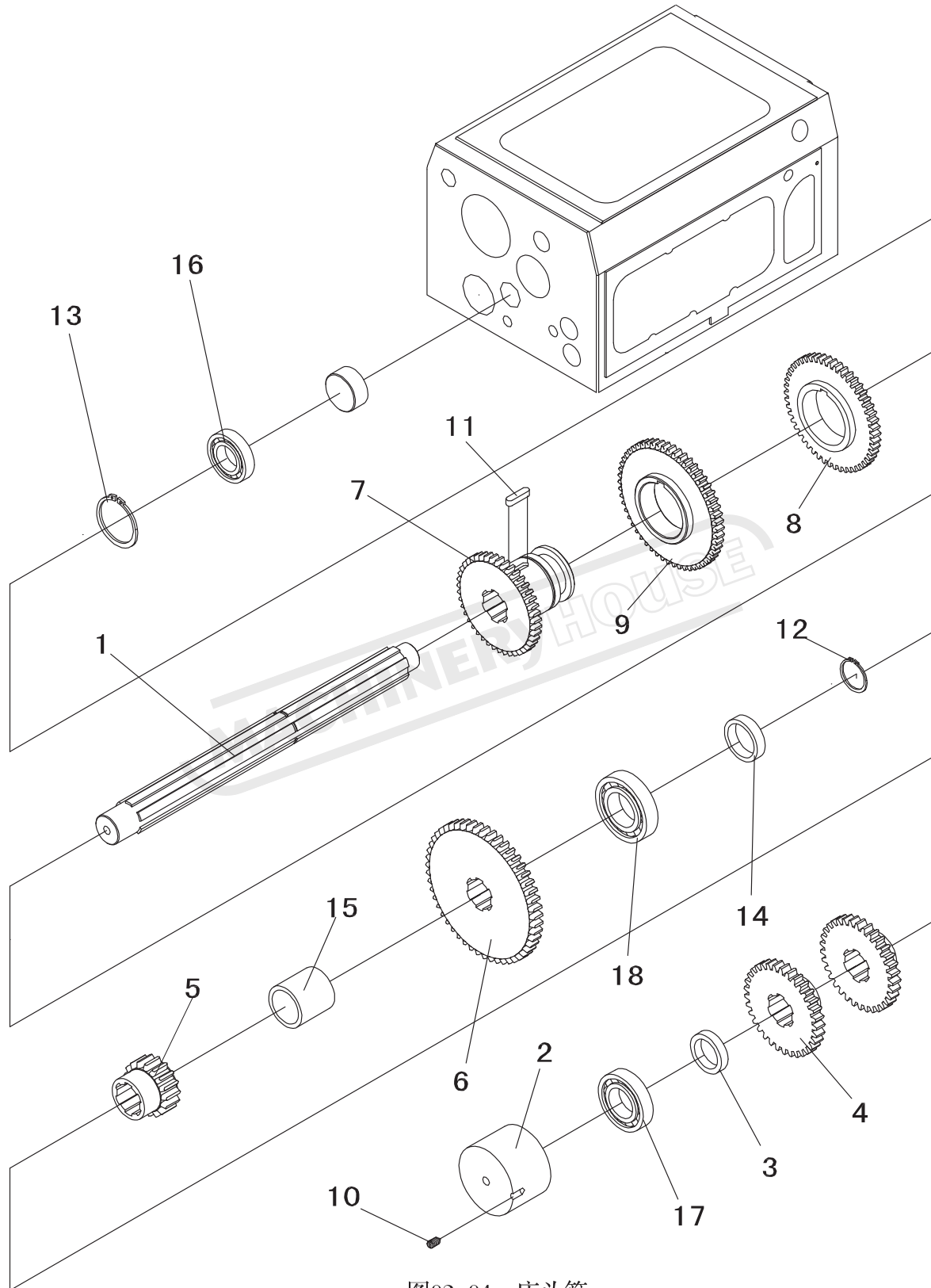
## 床头箱 HEADSTOCK

图上序号 POSITION No.	件号 PART No.	名称 DESCRIPTION	数量 Q'TY	附注 REMARKS
1	CW6163C-02-043A	II轴 SHAFT	1	
2	CW6163C-02-044	轴承套 BEARING HOUSING	1	
3	CW6163C-02-045	套 SPACER	1	
4	CW6163C-02-047	齿轮 GEAR	2	
5	CW6163C-02-048	齿轮 GEAR	1	
6	CW6163C-02-049	齿轮 GEAR	1	
7	CW6163C-02-050A	齿轮 GEAR	1	
8	CW6163C-02-051A	齿轮 GEAR	1	
9	CW6163C-02-052B	齿轮 GEAR	1	
10	GB71	螺钉 SCREW M8X12	1	
11	GB1096	平键 FLAT KEY 8X7X32	1	
12	GB894.1	弹性挡圈 SNAP RING 40	1	
13	GB894.1	弹性挡圈 SNAP RING 65	1	
14	Q43-1	内隔套 SPACER 40X12	1	
15	Q43-1	内隔套 SPACER 40X50	1	
16	GB276-64	轴承 BEARING 308	1	
17	GB276-64	轴承 BEARING 207	1	
18	GB276-64	轴承 BEARING 208	1	

Purchase Parts

CW6163C



图02-05 床头箱  
FIG02-05 HEADSTOCK

CW6163C

Purchase Parts

部别 02  
GROUP  
插图号 02-05  
FIG No.

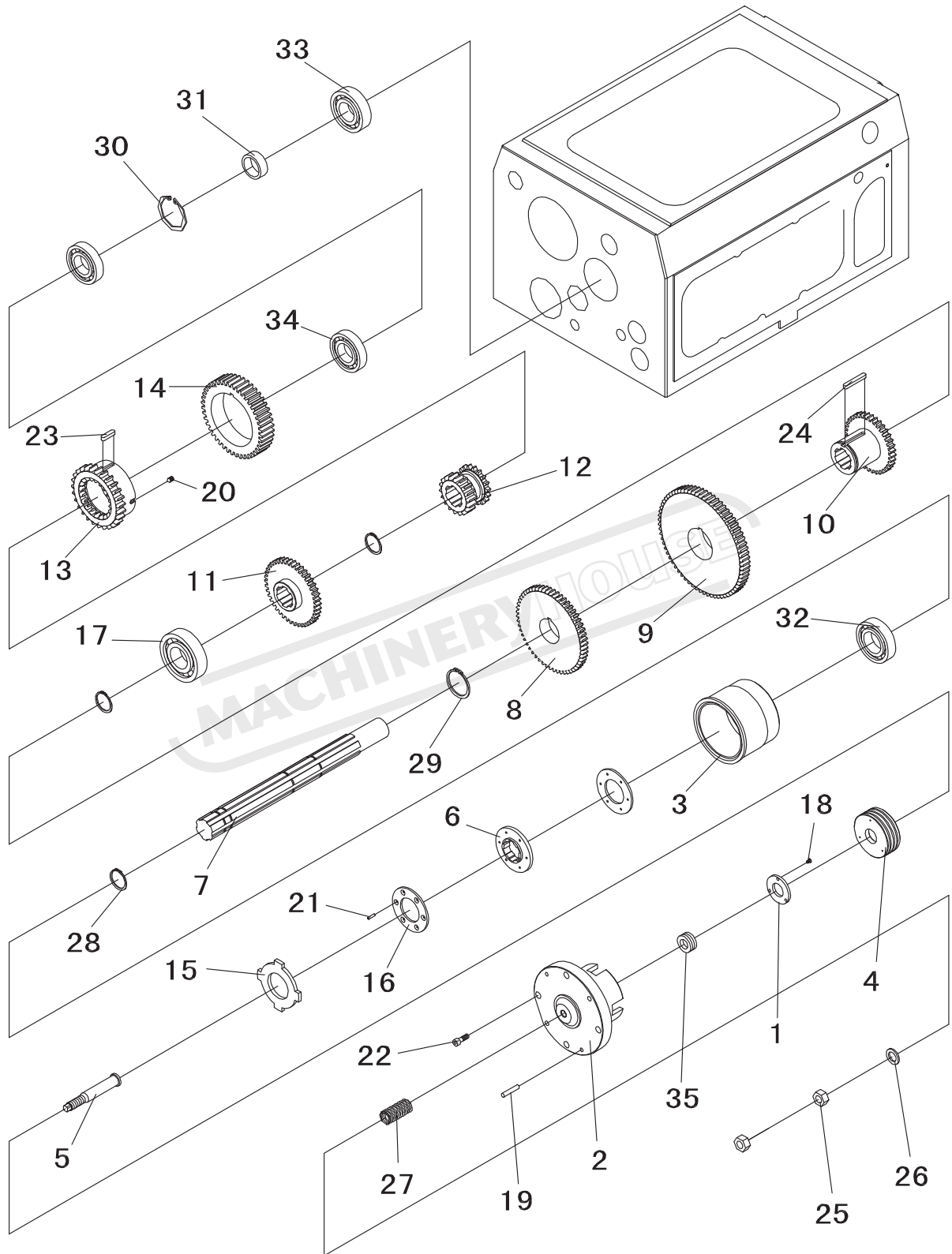
## 床头箱 HEADSTOCK

图上序号 POSITION No.	件号 PART No.	名称 DESCRIPTION	数量 Q'TY	附注 REMARKS
1	CW6163C-02-031	垫 GASKET	1	
2	CW6163C-02-053	油缸体 OIL CYLINDER BODY	1	
3	CW6163C-02-054	座体 HOUSING	1	
4	CW6163C-02-055	活塞 PISTON	1	
5	CW6163C-02-056	活塞杆 PISTON ROD	1	
6	CW6163C-02-174/1	刹车内片 INNER FRICTION DISC	1	
7	CW6163C-02-058	III轴 SHAFT	1	
8	CW6163C-02-059A	齿轮 GEAR	1	
9	CW6163C-02-060A	齿轮 GEAR	1	
10	CW6163C-02-061A	齿轮 GEAR	1	
11	CW6163C-02-062	齿轮 GEAR	1	
12	CW6163C-02-063	齿轮 GEAR	1	
13	CW6163C-02-064	齿轮 GEAR	1	
14	CW6163C-02-065	齿轮 GEAR	1	
15	CW6163C-02-173	刹车外片 OUTER FRICTION DISC	1	
16	CW6163C-02-174/2	刹车片 FRICTION DISC	2	
17	GB276-64	轴承 BEARING 208	1	
18	GB68	螺钉 SCREW M6X10	3	
19	GB118	圆锥销 TAPER PIN	2	
20	GB71	螺钉 SCREW M8X12	1	
21	GB1527	铜管 COPPER PIPE $\phi$ 4X0.5X16M	6	
22	GB70	螺钉 SCREW M8X25	4	
23	GB1096	平键 FLAT KEY 8X7X25	1	
24	GB1096	平键 FLAT KEY 8X7X56	1	
25	GB6172	螺母 NUT M16	2	
26	GB972	垫圈 WASHER 16	1	
27	GB2087	弹簧 SPRING 5X28X58	1	
28	GB894.1	弹性挡圈 SNAP RING 45	3	
29	GB894.1	弹性挡圈 SNAP RING 75	1	
30	GB893.1	弹性挡圈 SNAP RING 80	1	
31	CW6163C-02-201	隔套 SPACER	1	
32	GB276-64	轴承 BEARING 209	1	
33	GB276-64	轴承 BEARING 308	1	
34	GB276-64	轴承 BEARING D208	2	
35	JB/GQ0326	密封圈 SEAL RING 20X35	1	
35	JB/GQ0326	密封圈 SEAL RING B-20X35	1	
35	JB/GQ0326	密封圈 SEAL RING C-20X35	1	

Purchase Parts

CW6163C



图02-06 床头箱  
FIG02-06 HEADSTOCK

**CW6163C****Purchase Parts**

部别 02  
GROUP  
插图号 02-06  
FIG No.

## 床头箱 HEADSTOCK

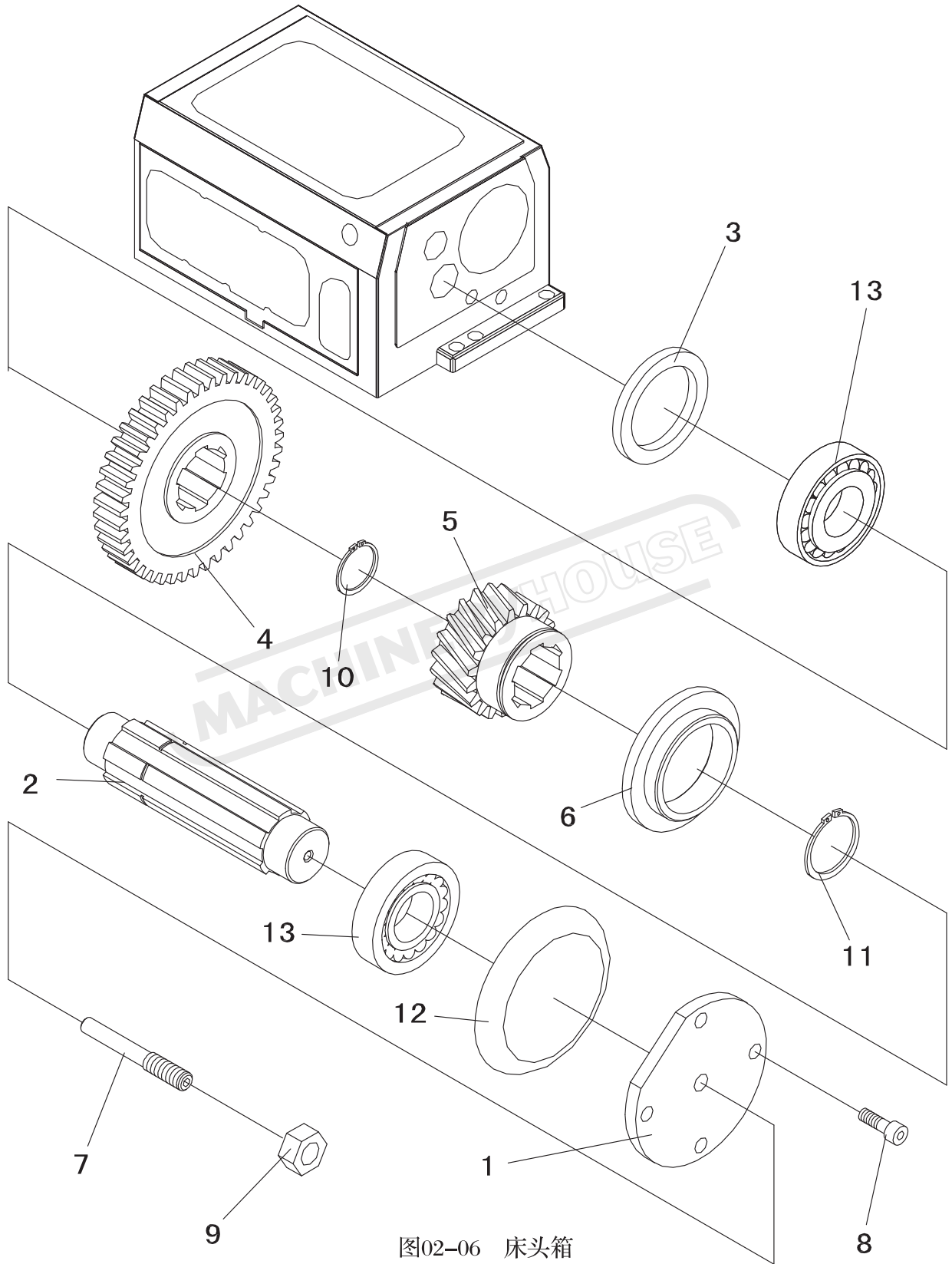
图上序号 POSITION No.	件号 PART No.	名称 DESCRIPTION	数量 Q'TY	附注 REMARKS
1	CW6163C-02-095	法兰盘 FLANGE	1	
2	CW6163C-02-071	V轴 SHAFT	1	
3	CW6163C-02-072	垫 SPACER	1	
4	CW6163C-02-074	齿 轮 GEAR	1	
5	CW6163C-02-075	齿 轮 GEAR	1	
6	CW6163C-02-076	拨 套 SLEEVE	1	
7	CW6163C-02-077	螺 钉 SCREW	1	
8	GB70	螺 钉 SCREW M8X20	4	
9	GB6172	螺 母 NUT M16	1	
10	GB894.1	弹性挡圈 SNAP RING 60	1	
11	GB894.1	弹性挡圈 SNAP RING 80	1	
12	JB/GQ0464	顶 盘 SPACER 110	1	
13	GB298-64	轴 承 BEARING 7310	2	

Purchase Parts

CW6163C



图02-07 床头箱  
FIG02-07 HEADSTOCK



CW6163C

Purchase Parts

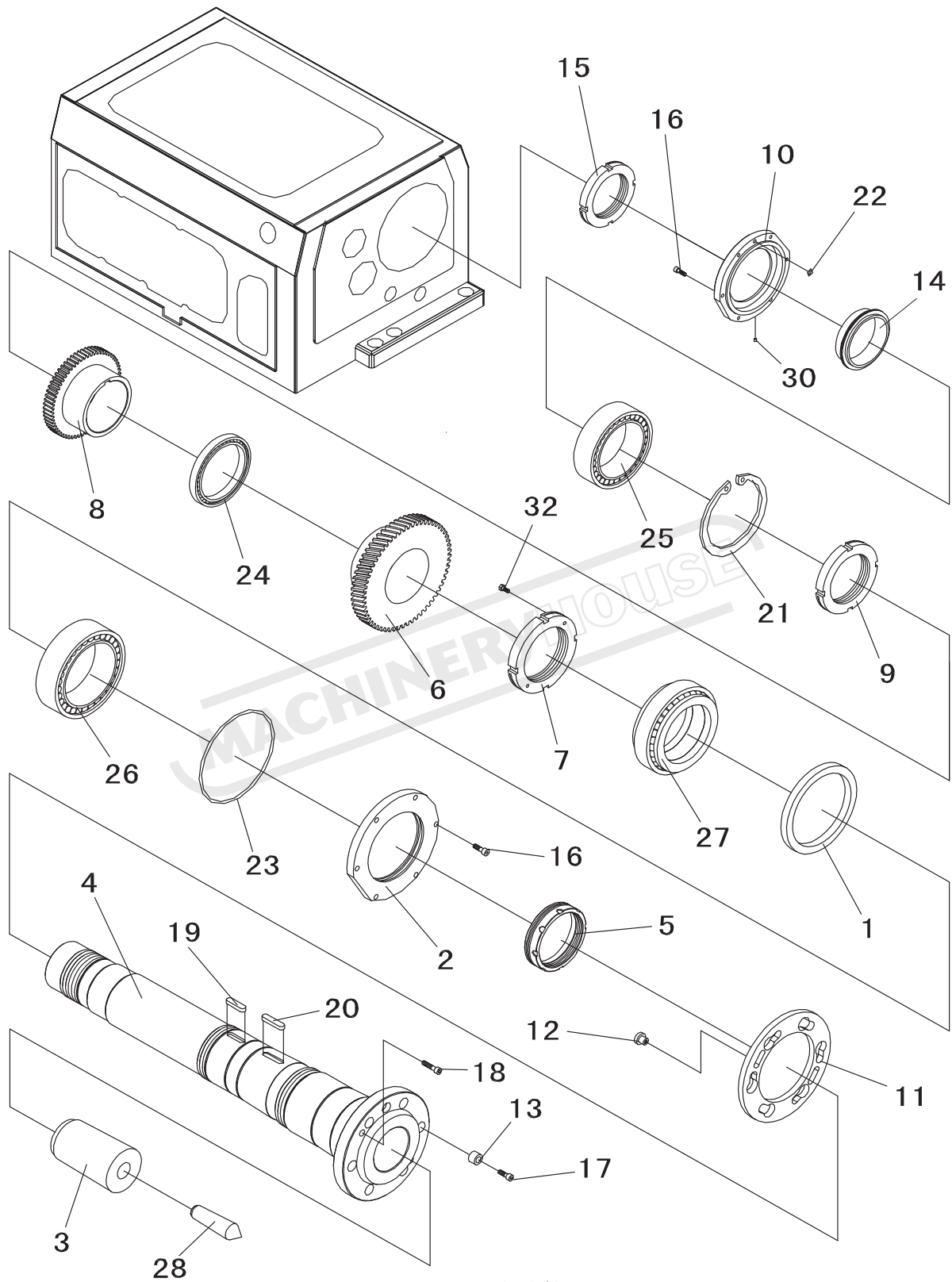
部别 02  
GROUP  
插图号 02-07  
FIG No.

## 床头箱 HEADSTOCK

图上序号 POSITION No.	件号 PART No.	名称 DESCRIPTION	数量 Q'TY	附注 REMARKS
1	CW6163C-02-084	套 SLEEVE	1	
2	CW6163C-02-082	调整法兰盘 ADJUSTMENT FLANGE	1	
3	CW6163C-02-079	顶 尖 套 GENTER SLEEVE	1	
4	CW6163C-02-080A	主 轴 MAIN SPINDLE	1	C11主轴SPINDLE
5	CW6163C-02-081	螺 帽 NUT	1	
6	CW6163C-02-086A	大 齿 轮 LARGE GEAR	1	
7	CW6163C-02-195	带锁紧槽圆螺母 LOCK NUT	1	
8	CW6163C-02-098A	齿 轮 GEAR	1	
9	CW6163C-02-198	圆 螺 母 ROUND NUT	1	
10	CW6163C-02-101	法 兰 盘 FLANGE	1	
11	CW6163C-02-078A	转 垫 TURNING PAD	1	C11主轴SPINDLE
12	CW6163C-02-179A	定 位 套 LOCATION BOLT	1	C11主轴SPINDLE
13	CW6163C-02-087A	传 动 键 DRIVING KEY	1	C11主轴SPINDLE
14	CW6163C-02-099	挡 油 环 OIL RING	1	
15	JB/GQ0176	圆 螺 母 ROUND NUT M130X2	1	
16	GB70	螺 钉 SCREW M8X25	12	
17	GB70	螺 钉 SCREW M10X30	1	
18	GB70	螺 钉 SCREW M10X45	2	
19	GB1096	平 键 FLAT KEY 16X10X40	1	
20	GB1096	平 键 FLAT KEY 16X10X70	1	
21	GB893.1	弹 性 挡 圈 SNAP RING 200	1	
22	GB3452.1	O型密封圈 O-RING 11.2X2.65	1	
23	GB3452.1	O型密封圈 O-RING 236X5.3	1	
24	GB276-64	轴 承 BEARING 128	1	
25	GB285-64	轴 承 BEARING D3182126	1	
26	GB285-64	轴 承 BEARING D3182132K	1	
27	GB285-64	轴 承 BEARING 4D2268132	1	
28	JB2887	顶 尖 CENTER DGM5	1	
30	JB/GQ0466	堵 塞 PLUG 10	1	
32	GB5783	螺 钉 SCREW M8X20	2	

Purchase Parts

CW6163C



图02-08 床头箱  
FIG02-08 HEADSTOCK

CW6163C

Purchase Parts

部别 02  
GROUP  
插图号 02-08  
FIG No.

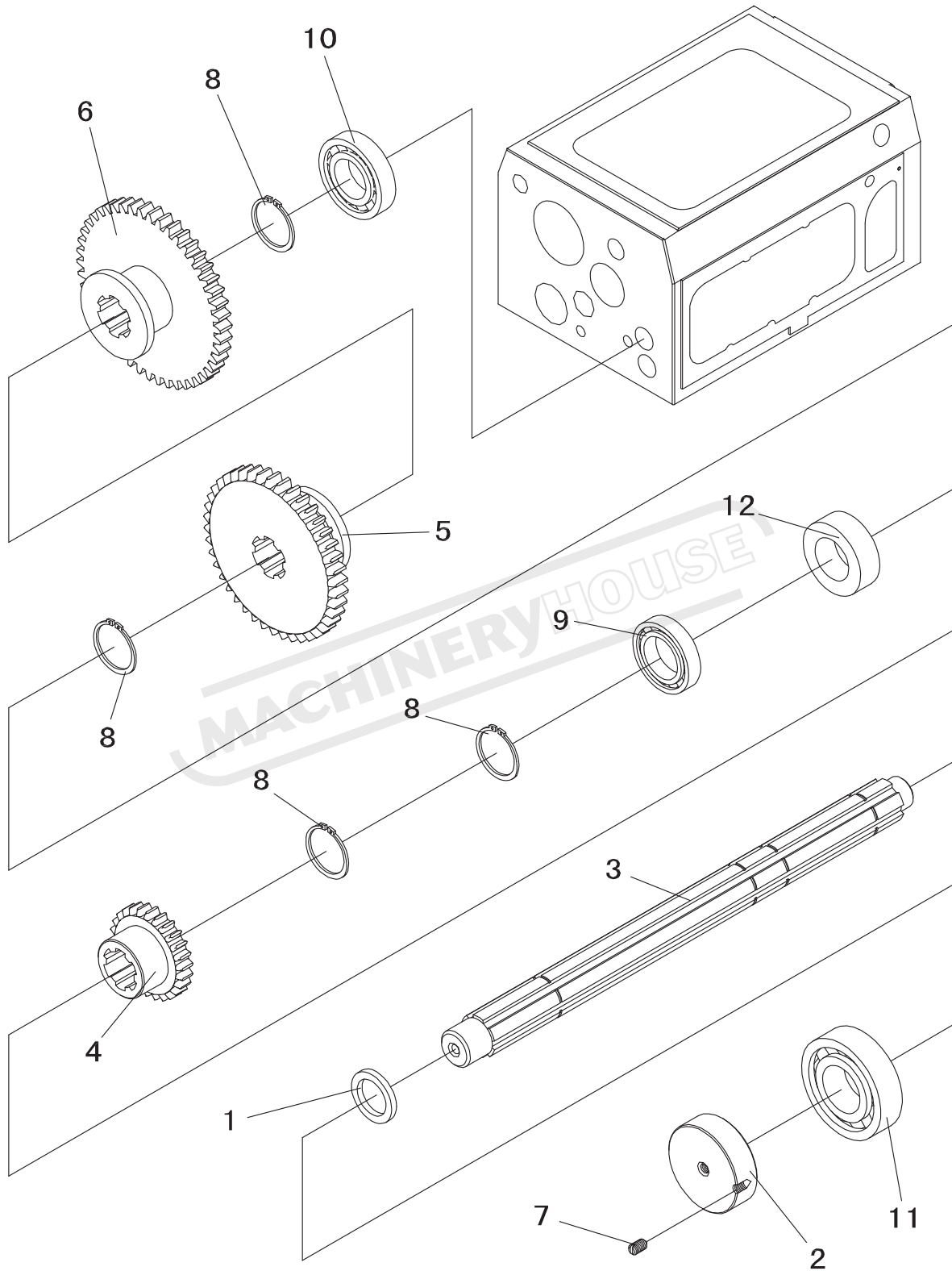
床头箱  
HEADSTOCK

图上序号 POSITION No.	件号 PART No.	名称 DESCRIPTION	数量 Q'TY	附注 REMARKS
1	CW6163C-02-102	垫 GASKET	1	
2	CW6163C-02-103	堵 PLUG	1	
3	CW6163C-02-104	VIII轴 SHAFT	1	
4	CW6163C-02-105	齿 轮 GEAR	1	
5	CW6163C-02-106	齿 轮 GEAR	1	
6	CW6163C-02-107	齿 轮 GEAR	1	
7	GB71	螺 钉 SCREW M8X12	1	
8	GB894.1	弹性挡圈 SNAP RING 35	4	
9	GB276-64	轴 承 BEARING 107	1	
10	GB276-64	轴 承 BEARING 205	1	
11	GB276-64	轴 承 BEARING 306	1	
12	JB/GQ0453	内 隔 套 SPACER 35X20	1	

Purchase Parts

CW6163C



图02-09 床头箱  
FIG02-09 HEADSTOCK

CW6163C

Purchase Parts

部别 02  
GROUP  
插图号 02-09  
FIG No.

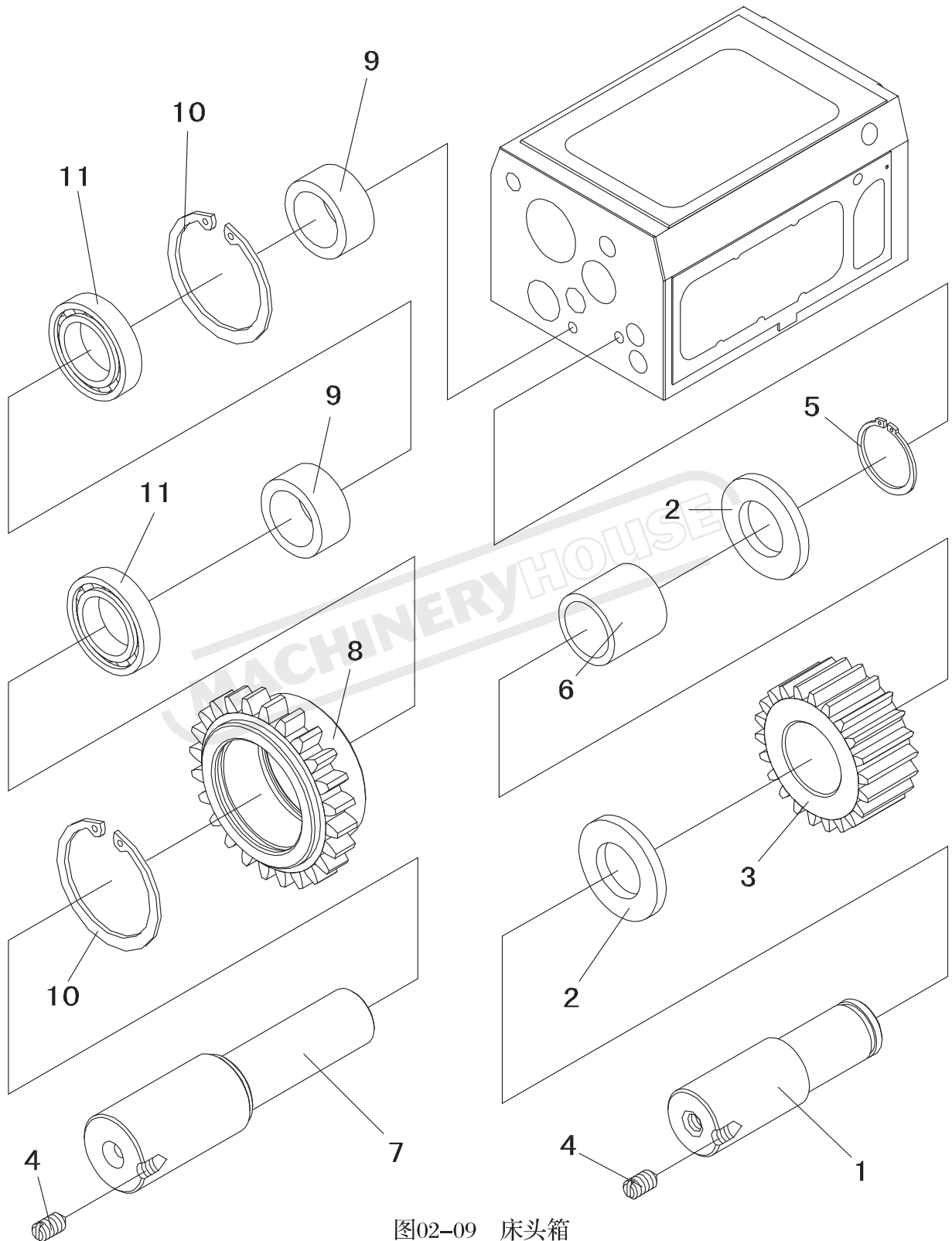
## 床头箱 HEADSTOCK

图上序号 POSITION No.	件号 PART No.	名称 DESCRIPTION	数量 Q'TY	附注 REMARKS
1	CW6163C-02-108	IX轴 SHAFT	1	
2	CW6163C-02-109	垫 SPACER	2	
3	CW6163C-02-110	齿 轮 GEAR	1	
4	GB71	螺 钉 SCREW M8X12	2	
5	GB894.1	弹性挡圈 SNAP RING 25	1	
6	CW6163C-02-202	轴 套 SHAFT SLEEVE D-铜32n6X30	1	
7	CW6163C-02-034A	VIII轴 SHAFT	1	
8	CW6163C-02-035C	齿 轮 GEAR	1	
9	Q43-1	轴 套 SHAFT SLEEVE 25X16	1	
9	CW6163C-02-208	套 SLEEVE	1	
10	GB893.1	弹性挡圈 SNAP RING 47	2	
11	GB276-64	轴 承 BEARING D105	2	

Purchase Parts

CW6163C



图02-10 床头箱  
FIG02-10 HEADSTOCK

CW6163C

Purchase Parts

部别 02  
GROUP  
插图号 02-10  
FIG No.

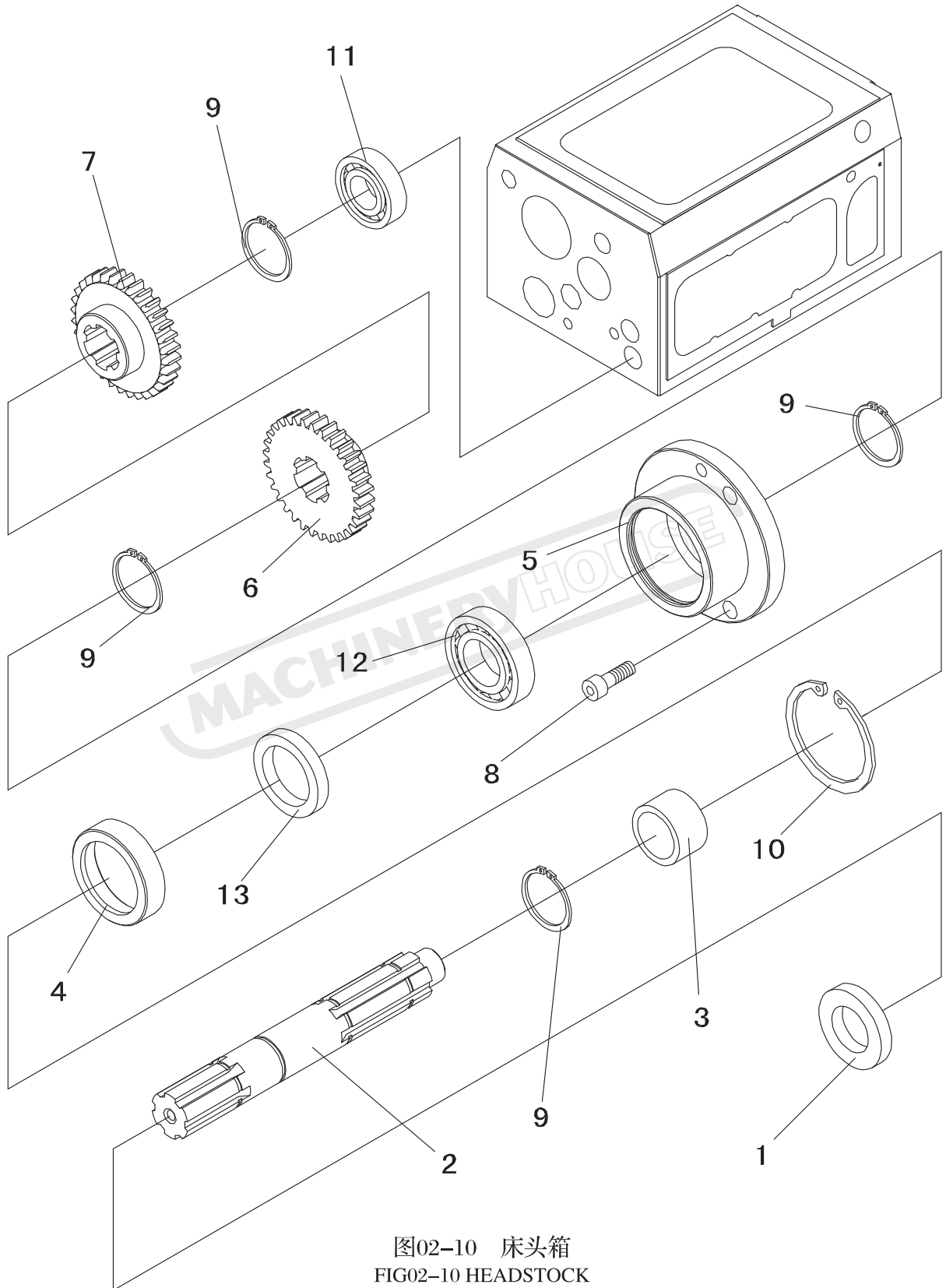
床头箱  
HEADSTOCK

图上序号 POSITION No.	件号 PART No.	名称 DESCRIPTION	数量 Q'TY	附注 REMARKS
1	CW6163C-07-017	挡 圈 SPACER	1	
2	CW6163C-02-111	IX轴 SHAFT	1	
3	CW6163C-02-112	套 SLEEVE	1	
4	CW6163C-02-113	环 RING	1	
5	CW6163C-02-114	法 兰 盘 FLANGE	1	
6	CW6163C-02-115	齿 轮 GEAR	1	
7	CW6163C-02-116	齿 轮 GEAR	1	
8	GB70	螺 钉 SCREW M8X20	3	
9	GB894.1	弹性挡圈 SNAP RING 35	4	
10	GB893.1	弹性挡圈 SNAP RING 72	1	
11	GB276-64	轴 承 BEARING 305	1	
12	GB276-64	轴 承 BEARING 207	1	
13	GB9877.1	密 封 圈 SEAL RING B-45X62X8	1	

Purchase Parts

CW6163C



图02-11 床头箱  
FIG02-11 HEADSTOCK



CW6163C

Purchase Parts

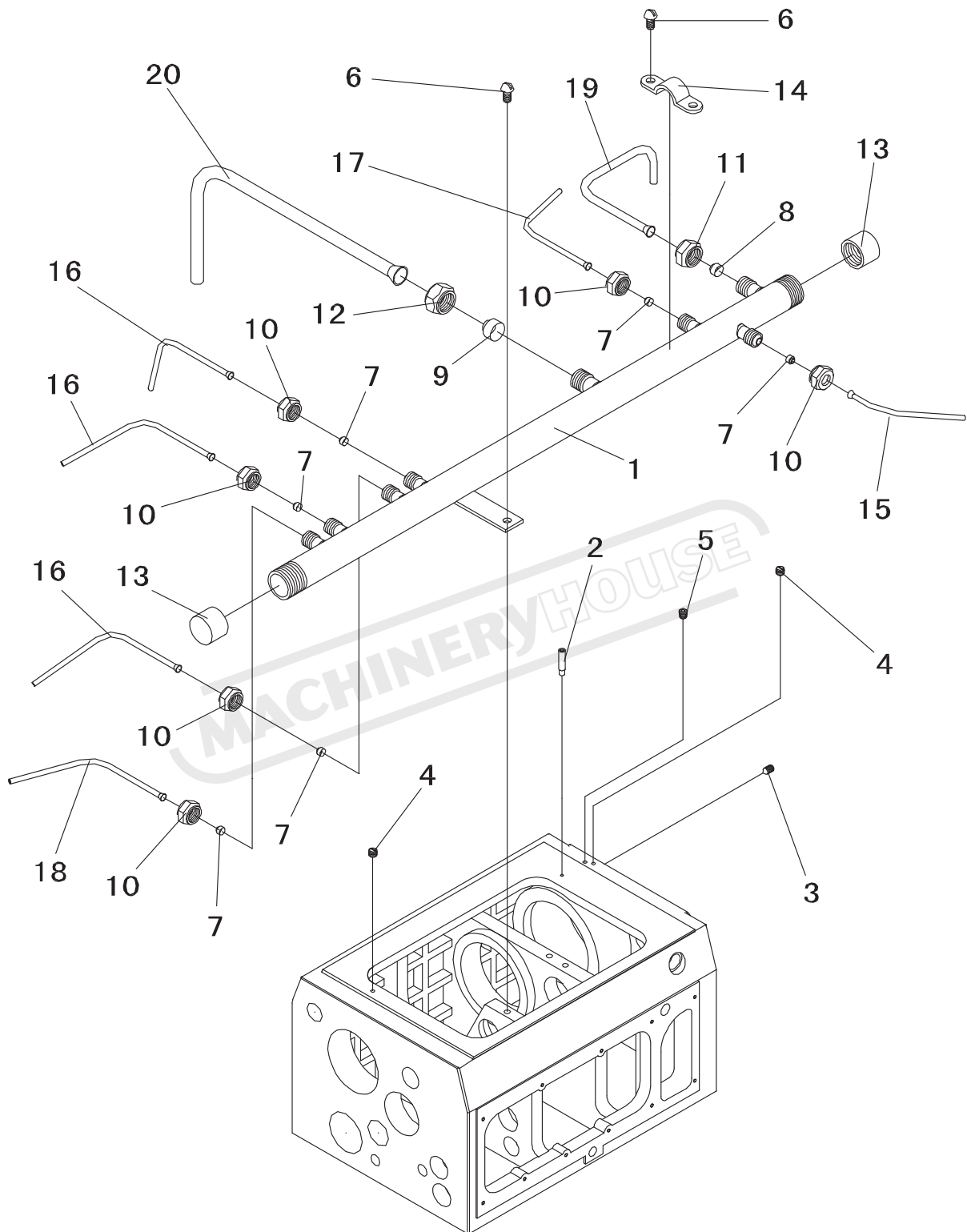
部别 02  
GROUP  
插图号 02-11  
FIG No.

床头箱  
HEADSTOCK

图上序号 POSITION No.	件号 PART No.	名称 DESCRIPTION	数量 Q'TY	附注 REMARKS
1	CW6163C-02-167	分 油 管 OIL DISTRIBUTION PIPE	1	
2	CW6163C-02-196	调 整 堵 PLUG	1	
3	GB71	螺 钉 SCREW M8X12	1	
4	GB73	螺 钉 SCREW M10X12	1	
5	JB/GQ0318	油 塞 PLUG Z1/8"	1	
6	GB67	螺 钉 SCREW M6X12	3	
7	GB5646	扩口式管接头管套 EXPANDING TUBE CONNECTOR 4	6	
8	GB5646	扩口式管接头管套 EXPANDING TUBE CONNECTOR 6	1	
9	GB5646	扩口式管接头管套 EXPANDING TUBE CONNECTOR 10	2	
10	Y91-1	管 接 头 螺 母 PIPE JOINT NUT M10X1	6	
11	Y91-1	管 接 头 螺 母 PIPE JOINT NUT M12X1.25	1	
12	Y91-1	管 接 头 螺 母 PIPE JOINT NUT M16X1.5	2	
13	JB/GQ0314	封 口 管 螺 母 CLOSED TUBULAR NUT G1/2"	2	
14	JB/GQ0306	管 夹 PIPE CLAMP 23	1	
15	GB1527	铜 管 COPPER PIPE $\phi 6X0.5X180M$	1	
16	GB1527	铜 管 COPPER PIPE $\phi 4X0.5X450M$	3	
17	GB1527	铜 管 COPPER PIPE $\phi 4X0.5X190M$	1	
18	GB1527	铜 管 COPPER PIPE $\phi 4X0.5X230M$	1	
19	GB1527	铜 管 COPPER PIPE $\phi 6X0.5X180M$	1	
20	GB1527	铜 管 COPPER PIPE $\phi 10X1X520M$	1	

Purchase Parts

CW6163C



图02-12 床头箱  
FIG02-12 HEADSTOCK

CW6163C

Purchase Parts

部别 02  
GROUP  
插图号 02-12  
FIG No.

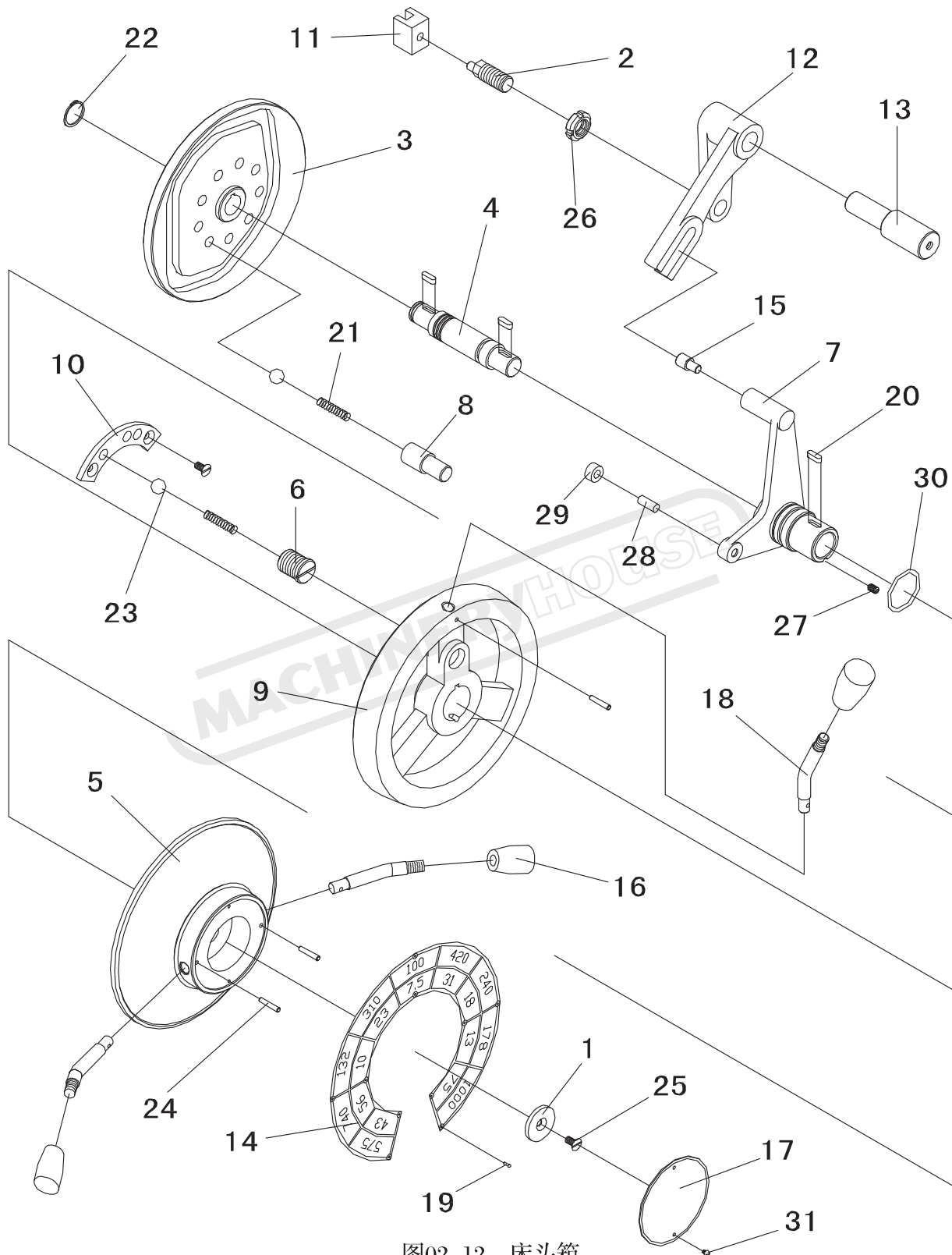
## 床头箱 HEADSTOCK

图上序号 POSITION No.	件号 PART No.	名称 DESCRIPTION	数量 Q'TY	附注 REMARKS
1	CW6163C-02-119	垫 WASHER	1	
2	CW6163C-02-137	调整螺钉 ADJUSTING SCREW	1	
3	CW6163C-02-148	凸 轮 CAM	1	
4	CW6163C-02-149	小 轴 SMALL SHAFT	1	
5	CW6163C-02-150	转 盘 DIAL DISC	1	
6	CW6163C-02-153	螺 帽 NUT	1	
7	CW6163C-02-152	杠 杆 SHIFTING ARM	1	
8	CW6163C-02-154	定 位 销 LOCATION PIN	1	
9	CW6163C-02-151	手 柄 座 HAND WHEEL	1	
10	CW6163C-02-155	定 位 垫 LOCATION PAD	1	
11	CW6163C-02-157	拨 块 SHIFTER FORK	1	
12	CW6163C-02-158	杠 杆 SHIFTER ARM	1	
13	CW6163C-02-159	小 轴 SMALL SHAFT	1	
14	CW6163C-02-161A	转 速 牌 PLATE	1	
15	CW6163C-02-172	销 子 PIN	1	
16	CW6163C-02-182	手 柄 HANDLE	5	
17	CW6163C-02-186	标 牌 PLATE	1	
18	CW6163C-02-200	手 柄 杆 SHANK ROD	1	
19	G867	铆 钉 RIVET	10	
20	GB1096	平 键 FLAT KEY 5X5X16	3	
21	GB2089	弹 簧 SPRING 1.6X12X22	2	
22	GB894.1	弹性挡圈 SNAP RING 20	1	
23	GB308	钢 球 STEEL BALL $\phi$ 14G200b	2	
24	GB117	圆 锥 销 TAPER PIN A-4X24	3	
25	GB68	螺 钉 SCREW M6X12	3	
26	CW6163C-02-036	调 节 帽 ADJUSTABLE CAP	1	
27	GB71	螺 钉 SCREW M6X12	3	
28	GB119	圆 柱 销 CYLINDRICAL PIN A-8X20	1	
29	Q99-1	套 SLEEVE B16	1	
30	GB3452.1	O型密封圈 O-RING 35.5X2.65	1	
31	GB67	螺 钉 SCREW M3X6-Zn.D	2	

Purchase Parts

CW6163C



图02-13 床头箱  
FIG02-13 HEADSTOCK

CW6163C

Purchase Parts

部别 02  
GROUP  
插图号 02-13  
FIG No.

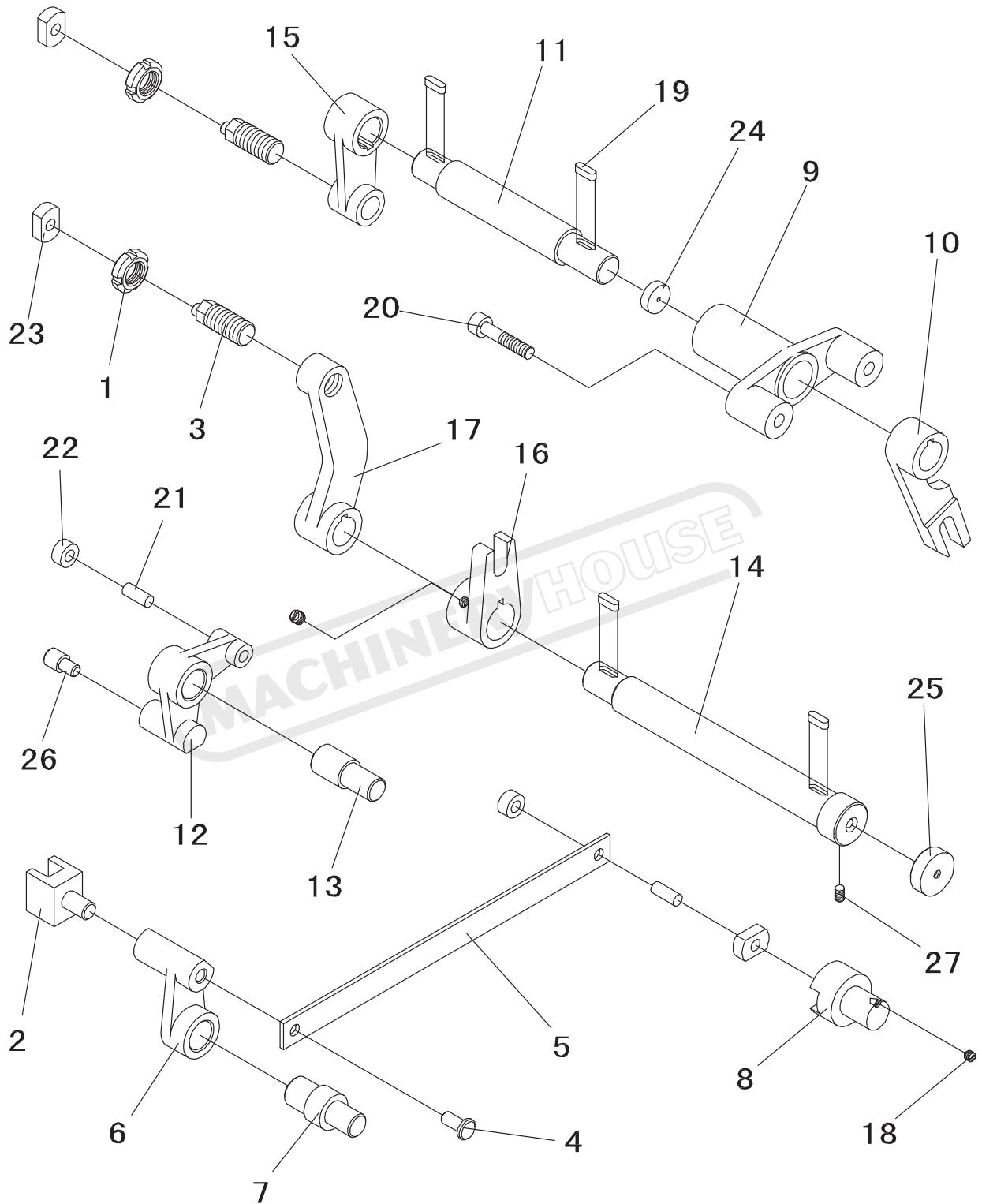
## 床头箱 HEADSTOCK

图上序号 POSITION No.	件号 PART No.	名称 DESCRIPTION	数量 Q'TY	附注 REMARKS
1	CW6163C-02-036	调节帽 ADJUSTABLE CAP	2	
2	CW6163C-02-138A	拨块 SHIFTER FORK	1	
3	CW6163C-02-137	调整螺钉 ADJUSTABLE SCREW	2	
4	CW6163C-02-129	销子 PIN	1	
5	CW6163C-02-130	连杆 CONNECTING PLATE	1	
6	CW6163C-02-135	杠杆 SHIFTER ARM	1	
7	CW6163C-02-136	小轴 SMALL SHAFT	1	
8	CW6163C-02-133	滑槽 SHIFTER ARM	1	
9	CW6163C-02-139	支架 SUPPORT	1	
10	CW6163C-02-140	杠杆 SHIFTER FORK	1	
11	CW6163C-02-141	轴 SHAFT	1	
12	CW6163C-02-143	杠杆 SHIFTER ARM	1	
13	CW6163C-02-144	小轴 SMALL SHAFT	1	
14	CW6163C-02-145	XV轴 SHAFT	1	
15	CW6163C-02-142A	杠杆 SHIFTER ARM	1	
16	CW6163C-02-146	杠杆 SHIFTER ARM	1	
17	CW6163C-02-147	杠杆 SHIFTER ARM	1	
18	GB71	螺钉 SCREW M6X8	1	
19	GB1096	平键 FLAT KEY 5X5X16	4	
20	GB70	螺钉 SCREW M8X40	2	
21	GB119	圆柱销 CYLINDRICAL PIN A-8X20	2	
22	Q99-1	套 SLEEVE B16	2	
23	CW6163C-02-204	滑块 BLOCK	2	
24	Q56-1	堵 PLUG 20n6	1	
25	Q56-1	堵 PLUG B30n6	1	
26	CW6163C-02-172	销子 PIN	1	
27	GB71	螺钉 SCREW M8X10	1	

Purchase Parts

CW6163C



图02-14 床头箱  
FIG02-14 HEADSTOCK

CW6163C

Purchase Parts

部别 02  
GROUP  
插图号 02-14  
FIG No.

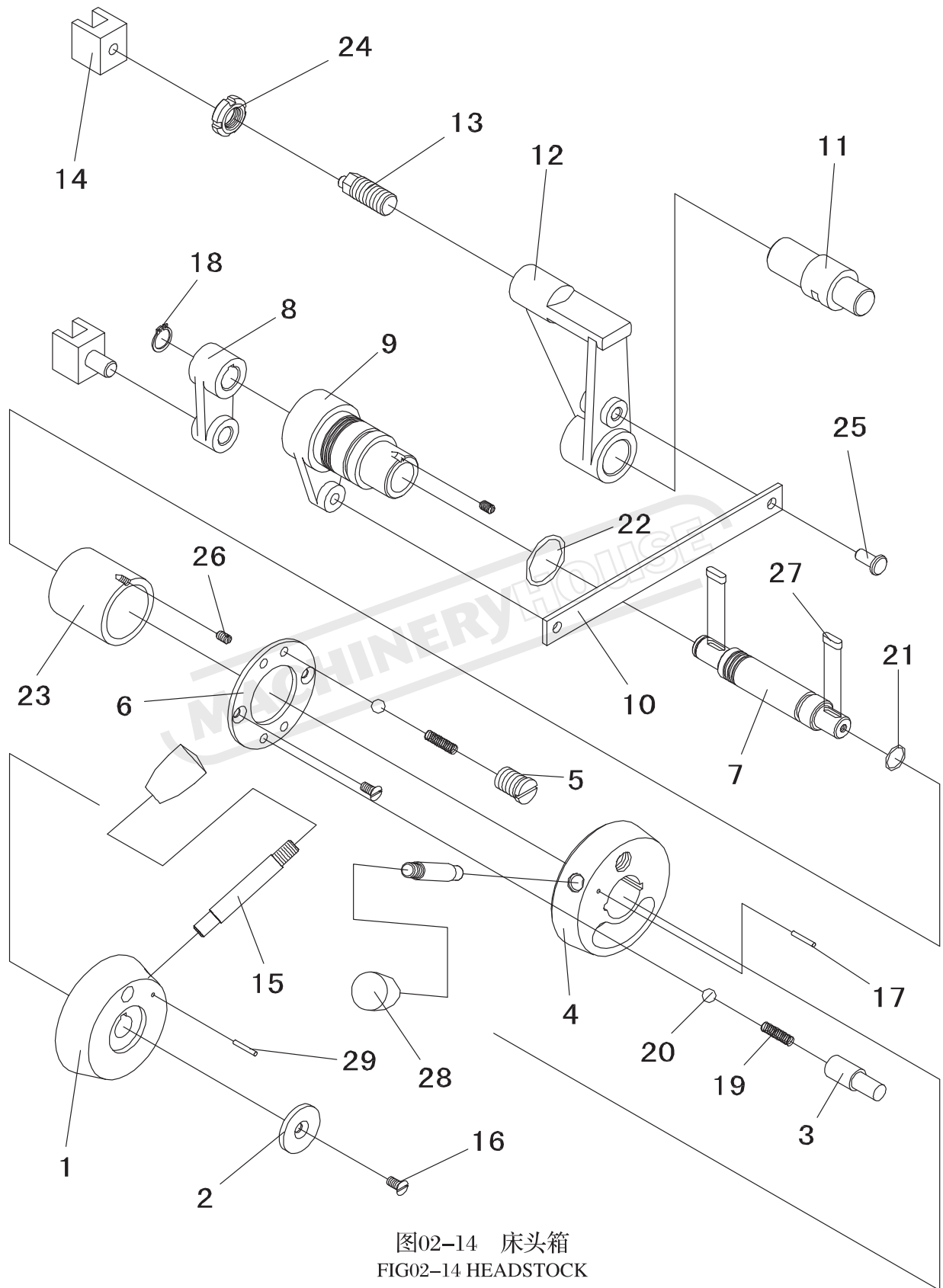
## 床头箱 HEADSTOCK

图上序号 POSITION No.	件号 PART No.	名称 DESCRIPTION	数量 Q'TY	附注 REMARKS
1	CW6163C-02-118	手柄座 HOUSING	1	
2	CW6163C-02-119	垫 WASHER	1	
3	CW6163C-02-120	定位套 LOCATION PLUG	1	
4	CW6163C-02-121	手柄座 HOUSING	1	
5	CW6163C-02-122	螺纹套 SCREWED SLEEVE	1	
6	CW6163C-02-123	定位垫圈 LOCATION PAD	1	
7	CW6163C-02-124	小轴 SMALL SHAFT	1	
8	CW6163C-02-125	杠杆 SHIFTER ARM	1	
9	CW6163C-02-127	套轴 SHIFTER ARM	1	
10	CW6163C-02-134	连杆 CONNECTING PLATE	1	
11	CW6163C-02-136	小轴 SMALL SHAFT	1	
12	CW6163C-02-135	杠杆 SHIFTER ARM	1	
13	CW6163C-02-137	调整螺钉 ADJUSTABLE SCREW	1	
14	CW6163C-02-138A	拨块 SHIFTER FORK	2	
15	CW6163C-02-199	手柄杆 SHANK ROD	2	
16	GB68	螺钉 SCREW M6X12	3	
17	GB117	圆锥销 TAPER PIN A-4X24	2	
18	GB894.1	弹性挡圈 SNAP RING 16	1	
19	GB2089	弹簧 SPRING 1X7X25	2	
20	GB308	钢球 STEEL BALL $\phi 9.5G200b$	2	
21	GB3452.1	O型密封圈 O-RING 17X2.65	1	
22	GB3452.1	O型密封圈 O-RING 35.5X2.65	1	
23	CW6163C-02-203	轴套 SLEEVE	1	
24	CW6163C-02-036	调节帽 ADJUSTABLE CAP	1	
25	CW6163C-02-129	销子 PIN	1	
26	GB71	螺钉 SCREW M6X12	2	
27	GB1096	平键 FLAT KEY 5X5X16	3	
28	CW6163C-02-182	手柄 HANDLE	2	

Purchase Parts

CW6163C

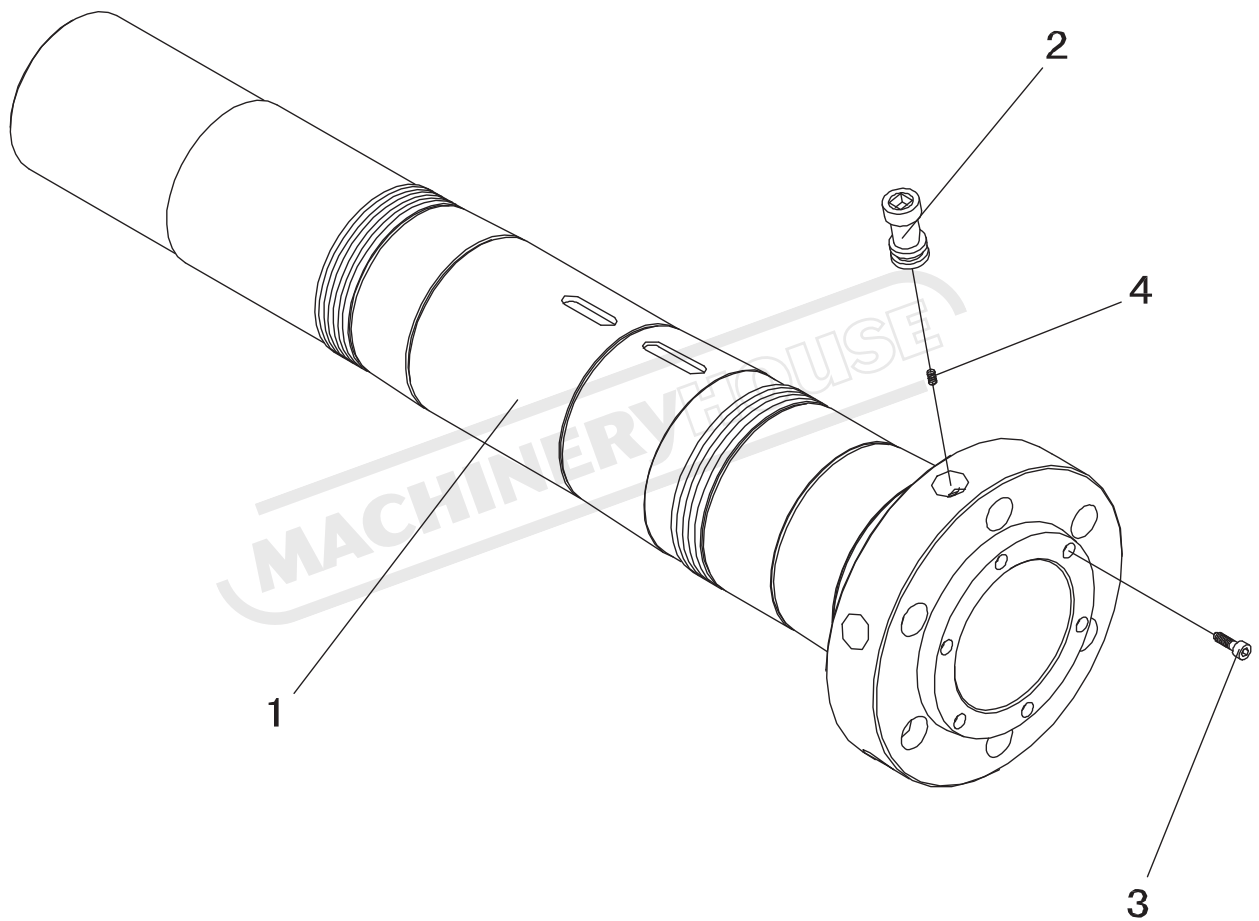

图B02-01 D11部主轴  
FIG B02-01 D11SPINDLE



**CW6163C****Purchase Parts**

部别 02  
GROUP  
插图号 B02-01  
FIG No.

床头箱  
HEADSTOCK

图上序号 POSITION No.	件号 PART No.	名称 DESCRIPTION	数量 Q'TY	附注 REMARKS
1	CW6163C-02D-080	主 轴 MAIN SPINDLE	1	D11 SPINDLE BORE OF $\phi$ 105mm
1	CW6163C-B02-015	主 轴 MAIN SPINDLE	1	D11 SPINDLE BORE OF $\phi$ 130mm
2	CW6163C-02D-201	凸 轮 CAM	6	D11 SPINDLE BORE OF $\phi$ 105mm
2	CW6163C-B02-201	凸 轮 CAM	6	D11 SPINDLE BORE OF $\phi$ 130mm
3	CW6163C-02D-202	限位螺钉 SPACING SCREW	6	D11 SPINDLE
4	GB2089	弹 簧 SPRING 1.2X7X30	6	D11 SPINDLE

MACHINERYHOUSE

Purchase Parts

CW6163C



图04-01 刀架及床鞍  
FIG04-01 SLIDE AND SADDLE

CW6163C

Purchase Parts

部别 04  
GROUP  
插图号 04-01  
FIG No.

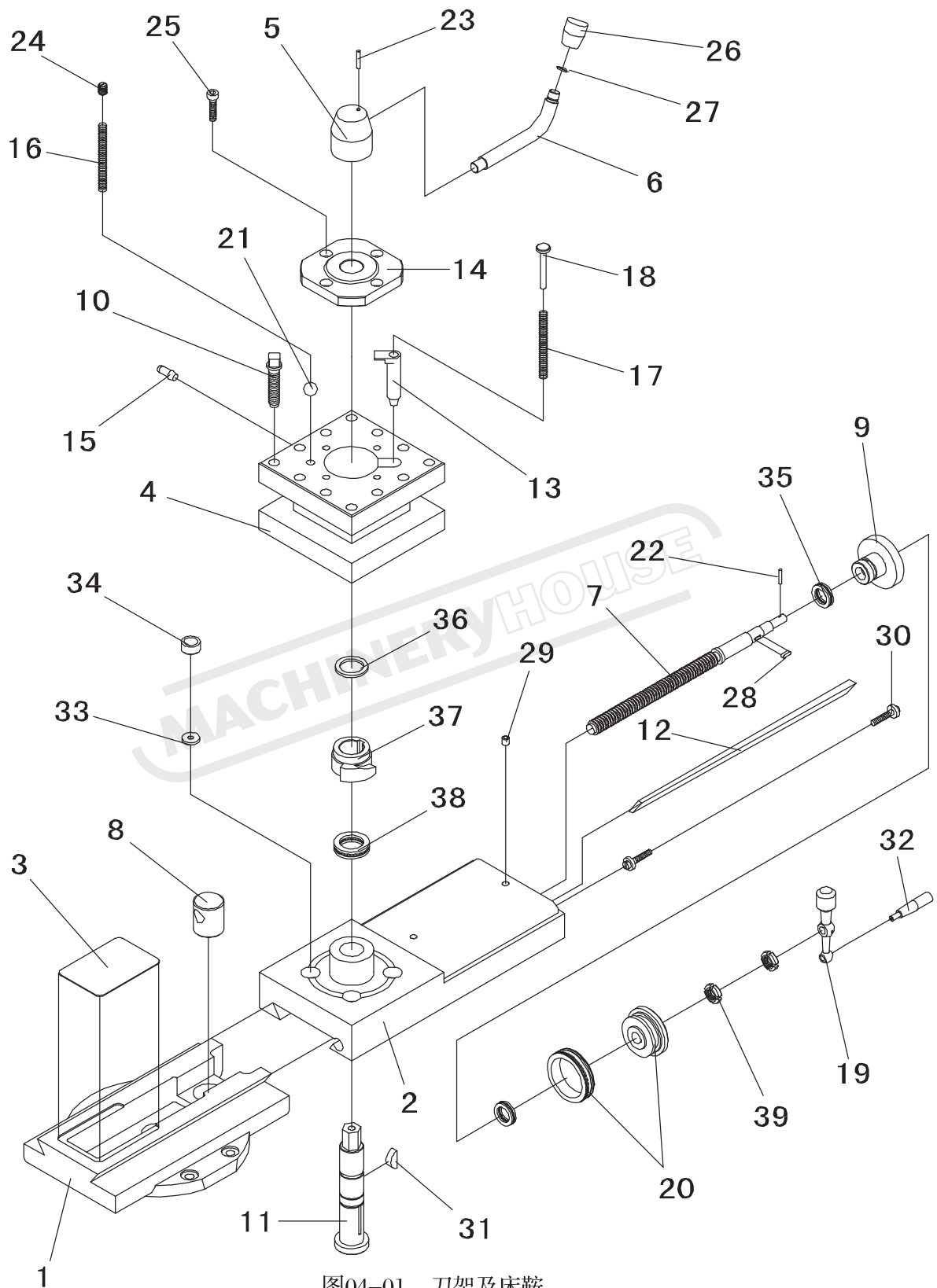
## 刀架及床鞍 SLIDE AND SADDLE

图上序号 POSITION No.	件号 PART No.	名称 DESCRIPTION	数量 Q'TY	附注 REMARKS
1	CW6163C-04-011A	转 盘 SWIVEL PLATE	1	
2	CW6163C-04-012	小刀架体 TOP SLIDE	1	
3	CW6163C-04-013	盖 板 COVER PLATE	1	
4	CW6163C-04-016	方 刀 架 TOOL POST	1	
5	CW6163C-04-017	手 柄 座 HOUSING	1	
6	CW6163C-04-018	手 柄 杆 SHANK ROD	1	
7	CW6163C-04-019	刀架螺杆 TOOL CARRIER SCREW	1	
8	CW6163C-04-020	螺 母 NUT	1	
9	CW6163C-04-021	法 兰 盘 FLANGE	1	
10	GB83	螺 钉 SCREW M16X70	12	
11	CW6163C-04-027	转 轴 SPIN BOLT	1	
12	CW6163C-04-024	刀架镶条 GIB STRIP	1	
13	CW6163C-04-023	柱 销 PLUG	1	
14	CW6163C-04-026	法 兰 盘 FLANGE	1	
15	CW6163C-04-025	止 销 钉 STOPING PIN	1	
16	CW6163C-04-028	压缩弹簧 PRESSED SPRING	1	
17	CW6163C-04-032	弹 簧 SPRING	1	
18	CW6163C-04-031	定 位 销 LOCATION PIN	1	
19	CW6163C-04-033	手 柄 体 HANDLE BODY	1	
20	JB/GQ0467	分 度 盘 DIAL RING B-80X18X100	1	套 SET
21	GB308	钢 球 STEEL BALL $\phi$ 21G200b	1	
22	GB117	圆 锥 销 TAPER PIN A-4X24	1	
23	GB117	圆 锥 销 TAPER PIN A-5X30	1	
24	GB78	螺 钉 SCREW M12X16	1	
25	GB70	螺 钉 SCREW M10X20	4	
26	CW6163C-04-035	手 柄 HANDLE	1	
27	GB895.2	轴用钢丝挡圈 SHAFT WIRE BLOCK RING 16	1	
28	GB1096	平 键 FLAT KEY 5X5X16	1	
29	GB1155	注 油 环 OIL NIPPLE 10	2	
30	CW6163C-05-023	调整螺钉 ADJUSTABLE SCREW	2	
31	GB1099	半 圆 键 WOODRUFF KEY 10X32	1	
32	GB4141.1	手 柄 HANDLE 8X63X16-DL <sub>3</sub> Cr	1	
33	CW6163C-04-030	垫 片 WASHER	4	
34	CW6163C-04-029	销 套 SPACER	4	
35	GB301-64	轴 承 BEARING 8104	2	
36	GB894.1	弹性挡圈 SNAP RING 35	1	
37	CW6163C-04-022	端面凸轮 CAM	1	
38	GB301-64	轴 承 BEARING 8107	1	
39	GB812	圆 螺 母 ROUND NUT M16X1.5	2	

## Purchase Parts

CW6163C



图05-01 刀架及床鞍  
FIG05-01 SLIDE AND SADDLE

CW6163C

Purchase Parts

部别 05  
GROUP  
插图号 05-01  
FIG No.

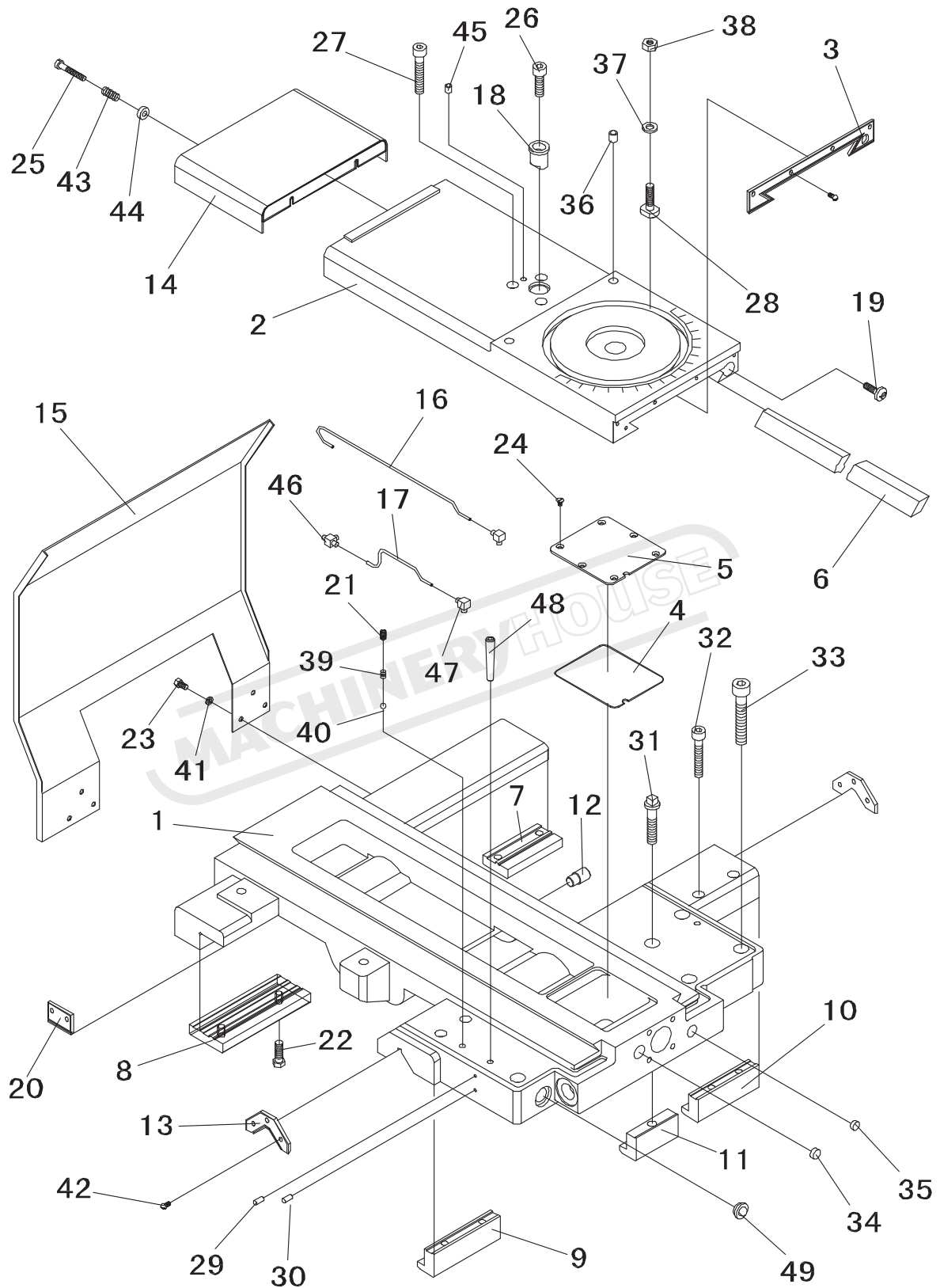
刀架及床鞍  
SLIDE AND SADDLE

图上序号 POSITION No.	件号 PART No.	名称 DESCRIPTION	数量 Q'TY	附注 REMARKS
1	CW6163C-05-011A	床 鞍 SADDLE CASTING	1	
2	CW6163C-05-012	刀架下部 CROSS-SLIDE	1	
3	CW6163C-05-018A	防 尘 板 ANTI-DUST PAD	1	
4	CW6163C-05-053	盖 板 COVER	1	
5	CW6163C-05-019	盖 板 COVER	1	
6	CW6163C-05-029	镶 条 GIB	1	
7	CW6163C-05-020	压 板 PRESSURE BLOCK	1	
8	CW6163C-05-021	压 板 PRESSURE BLOCK	1	
9	CW6163C-05-027	压 板 PRESSURE BLOCK	1	
10	CW6163C-05-028	压 板 PRESSURE BLOCK	1	
11	CW6163C-05-038	压 板 PRESSURE BLOCK	1	
12	CW6163C-05-051	顶 销 PIN	1	
13	CW6163C-05-035A	防 尘 板 ANTI-DUST PAD	2	
14	CW6163C-05-043	盖 板 COVER	1	
15	CW6163C-05-050	防 护 罩 SHIELD COVER	1	
16	SG79	软 塑 管 PLASTIC SOFT PIPE 流φ4X820	1	
17	SG79	软 塑 管 PLASTIC SOFT PIPE 流φ4X340	1	
18	CW6163C-05-015	固 定 套 LOCK BUSH	1	
19	CW6163C-05-023	调整螺钉 ADJUSTING SCREW	2	
20	CW6163C-05-037A	除 尘 板 ANTI-DUST PAD	2	
21	GB71	螺 钉 SCREW M10X16	1	
22	GB5782	螺 钉 SCREW M12X35	4	
23	GB5782	螺 钉 SCREW M8X16	6	
24	GB68	螺 钉 SCREW M6X12	6	
25	GB65	螺 钉 SCREW M6X40	2	
26	GB70	螺 钉 SCREW M12X35	3	
27	GB70	螺 钉 SCREW M12X70	1	
28	GB37	螺 钉 SCREW M12X45	4	

## Purchase Parts

CW6163C

部别 05  
GROUP  
插图号 05-01  
FIG No.

刀架及床鞍  
SLIDE AND SADDLE

图上序号 POSITION No.	件号 PART No.	名称 DESCRIPTION	数量 Q'TY	附注 REMARKS
29	GB119	圆柱销 CYLINDRICAL PIN A-8X16	1	
30	GB119	圆柱销 CYLINDRICAL PIN A-12X22	1	
31	GB83	螺钉 SCREW M16X80	1	
32	GB70	螺钉 SCREW M12X70	2	
33	GB70	螺钉 SCREW M16X75	2	
34	Q56-1	堵塞 PLUG 25	1	
35	Q56-1	堵塞 PLUG 22	2	
36	GB1155	注油杯 OIL NIPPLE 16	2	
37	GB97.1	垫圈 WASHER 12	4	
38	GB6170	螺母 NUP M16	4	
39	GB2089	弹簧 SPRING 1X7X17	1	
40	GB308	钢球 STEEL BALL $\phi$ 8G200b	1	
41	GB93	弹簧垫圈 SPRING WASHER 8	6	
42	GB67	螺钉 SCREW M6X12	6	
43	GB2089	弹簧 SPRING 2X10X28	2	
44	CW6163C-05-046	垫板 BED PIECE	2	
45	GB1155	注油杯 OIL NIPPLE 10	1	
46	JB/GQ0348	管接头 PIPE JOINT 4	1	
47	JB/GQ0348	管接头 PIPE JOINT 4	1	
48	GB118	圆锥销 ROUND TAPER PIN A-10X80	2	
49	GB1160.2	油标 OIL SEAL A-20	1	

CW6163C

Purchase Parts



图05-02 刀架及床鞍  
FIG05 02 SLIDE AND SADDLE

## Purchase Parts

CW6163C

部别 05  
GROUP  
插图号 05-02  
FIG No.

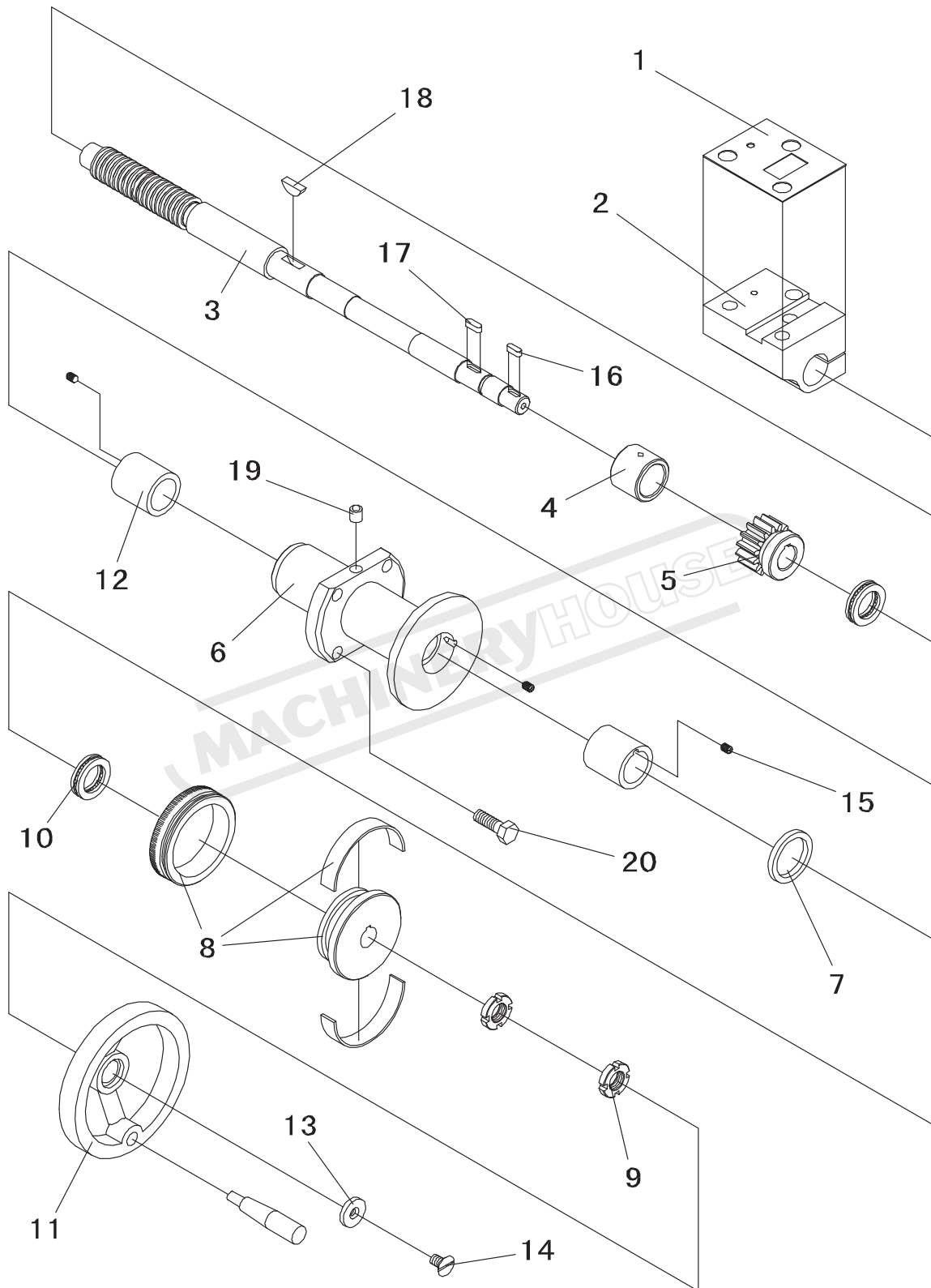
刀架及床鞍  
SLIDE AND SADDLE

图上序号 POSITION No.	件号 PART No.	名称 DESCRIPTION	数量 Q'TY	附注 REMARKS
1	CW6163C-05-014	调整垫片 ADJUSTING PLATE	4	
2	CW6163C-05-016	螺 母 NUT	1	
3	CW6163C-05-013A	丝 杠 LEAD SCREW	1	
4	CW6163C-05-044	轴 套 SPACER	1	
5	CW6163C-05-025	齿 轮 GEAR	1	
6	CW6163C-05-026	法 兰 盘 FLANGE	1	
7	JB/GQ0454	外 隔 套 SPACER	1	
8	JB/GQ0467	分 度 盘 SCALE RING B-100X18X100	1	套SET
9	GB812	圆 螺 母 ROUND NUT M18X1.5	2	
10	GB301-64	轴 承 BEARING 8104	2	
11	CWA6163C-05-049A	可折手轮 POP-OFF HANDLE	1	
12	JB/GQ0452	轴 套 SPACER C-28X40	2	
13	GB891	挡 圈 SNAP RING B-22	1	
14	GB68	螺 钉 SCREW M5X12	1	
15	GB71	螺 钉 SCREW M6X8	2	
16	GB1096	平 键 FLAT KEY 5X5X14	1	
17	GB1096	平 键 FLAT KEY 5X5X16	1	
18	GB1099	半 圆 键 WOODRUFF KEY 6X22	1	
19	GB1155	注 油 杯 OIL NIPPLE 10	2	
20	GB5783	螺 钉 SCREW M10X30	4	



CW6163C

Purchase Parts



图06-01 溜板箱

FIG06-01 APRON

## Purchase Parts

CW6163C

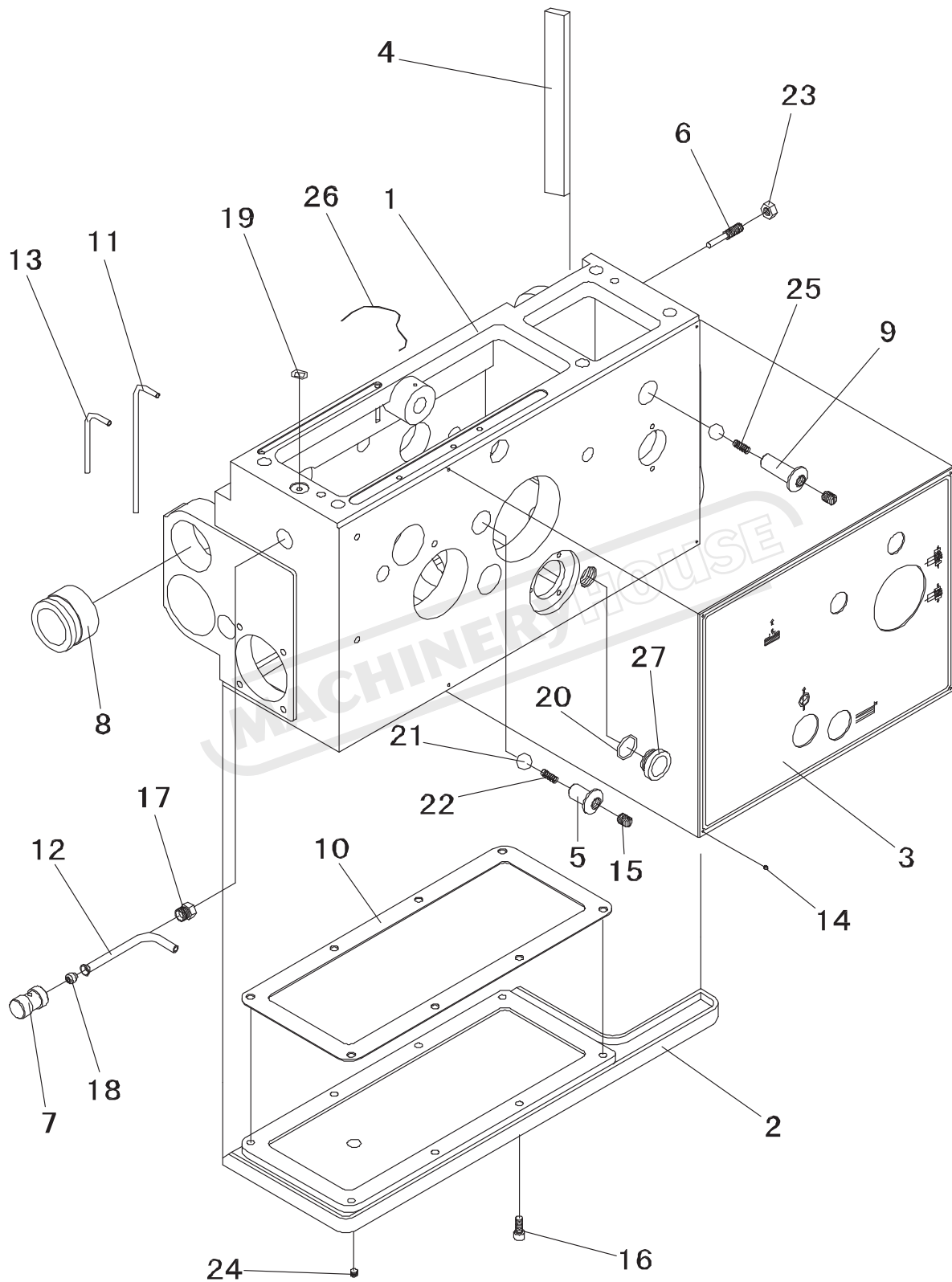
部别 06  
GROUP  
插图号 06-01  
FIG No.

溜板箱  
APRON

图上序号 POSITION No.	件号 PART No.	名称 DESCRIPTION	数量 Q'TY	附注 REMARKS
1	CW6163C-06-011	溜板箱体 APRON CASTING	1	
2	CW6163C-06-059	盖 COVER	1	
3	CW6163C-06-142A	面 板 PLATE	1	
4	CW6163C-06-038	镶 条 GIB	1	
5	CW6163C-06-078	套 SLEEVE	1	
6	CW6163C-06-034	螺 钉 SCREW	5	
7	CW6163C-06-062	油 塞 OIL PLUG	1	
8	CW6163C-06-035	套 SLEEVE	1	
9	CW6163C-06-138	套 SLEEVE	1	
10	CW6163C-06-127	垫 GASKET	1	
11	GB1527	铜 管 COPPER PIPE $\phi 6 \times 0.5 \times 160 \text{M}$	1	
12	GB1527	铜 管 COPPER PIPE $\phi 8 \times 1 \times 575 \text{M}$	1	
13	GB1527	铜 管 COPPER PIPE $\phi 6 \times 0.5 \times 60 \text{M}$	1	
14	GB67	螺 钉 SCREW M3X6-Zn.D	4	
15	GB71	螺 钉 SCREW M12X16	2	
16	GB70	螺 钉 SCREW M8X20	8	
17	GB5650	螺 栓 SCREW A-8	1	
18	GB5651	垫 CONE SPACER A-8	1	
19	GB3452.1	O型密封圈 O-RING 17X2.65	1	
20	JB1160.2	油 标 OIL WINDOW A-20	1	
21	GB308	钢 球 STEEL BALL $\phi 9.5 \text{G}200 \text{b}$	2	
22	GB2089	弹 簧 SPRING 1.6X8X22	1	
23	GB6172	螺 母 NUT M10	6	
24	JB/GQ0318	油 塞 OIL PLUG Z1/2"	1	
25	GB2089	弹 簧 SPRING 1.6X8X45	1	
26		羊 毛 线 WOOL ROPE 长160	1	
27	QJ/D2 06.08.1	油芯支持器 OIL CORE SUPPORT 0.5X25	8	

CW6163C

Purchase Parts



图06-02 溜板箱  
FIG06-02 APRON

## Purchase Parts

CW6163C

部别 06  
GROUP  
插图号 06-02  
FIG No.

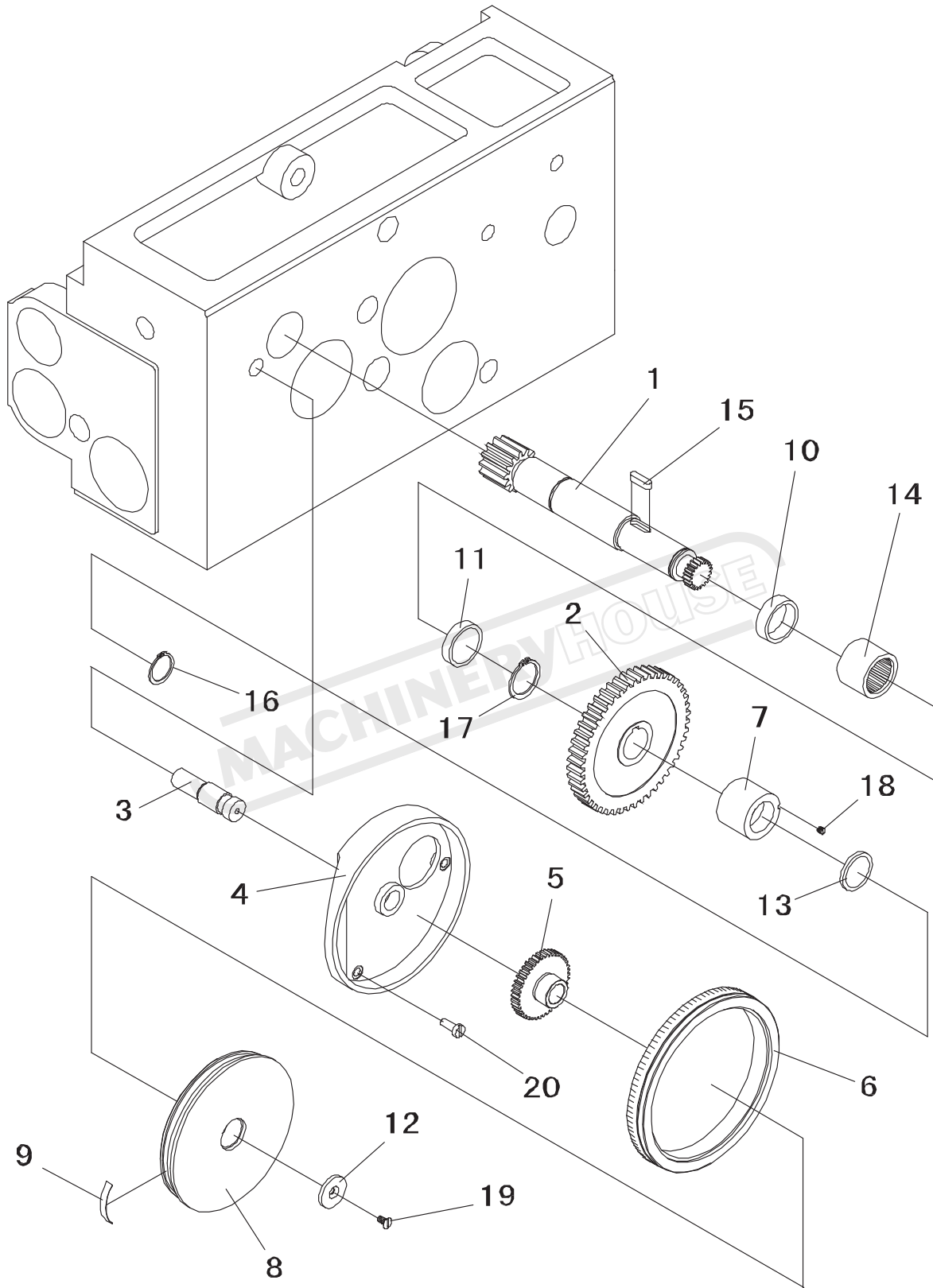
溜板箱  
APRON

图上序号 POSITION No.	件号 PART No.	名称 DESCRIPTION	数量 Q'TY	附注 REMARKS
1	CW6163C-06-012	VIII轴 SHAFT	1	
2	CW6163C-06-013	齿 轮 GEAR	1	
3	CW6163C-06-043	小 轴 SMALL SHAFT	1	
4	CW6163C-06-044	刻度环座 BUSH	1	
5	CW6163C-06-045	齿 轮 GEAR	1	
6	CW6163C-06-125	分 度 环 SCALE RING	1	
7	CW6163C-06-047	轴 套 SPACER	1	
8	CW6163C-06-046	刻度内环 GRADUATED INNER RING	1	
9	CW6163C-06-126	弹 簧 片 PLATE SPRING	1	
10	JB/GQ0453	内 隔 套 CONE SPACER 40X14	1	
11	JB/GQ0453	内 隔 套 CONE SPACER 40X10	1	
12	CW6163C-02-119	垫 WASHER	1	
13	JB/GQ0453	内 隔 套 CONE SPACER 35X4	1	
14	943/40	轴 承 BEARING 40X50X38	1	
15	GB1096	平 键 FLAT KEY 8X7X28	1	
16	GB894.1	弹性挡圈 SNAP RING 35	1	
17	GB894.1	弹性挡圈 SNAP RING 40	1	
18	GB71	螺 钉 SCREW M6X12	2	
19	GB68	螺 钉 SCREW M6X12	1	
20	GB65	螺 钉 SCREW M8X20	3	

CW6163C

Purchase Parts



图06-03 溜板箱  
FIG06-03 APRON

## Purchase Parts

CW6163C

部别 06  
GROUP  
插图号 06-03  
FIG No.

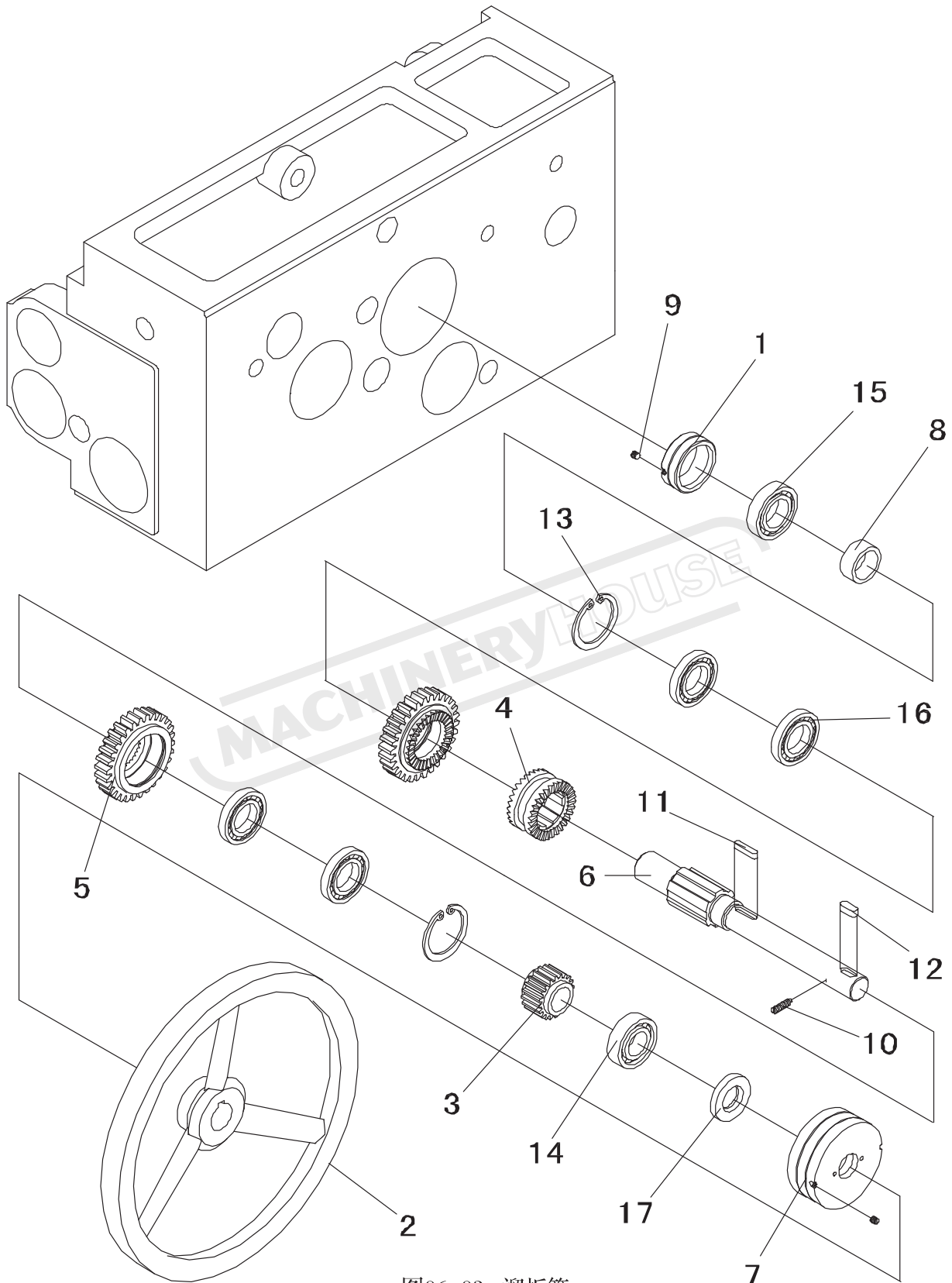
溜板箱  
APRON

图上序号 POSITION No.	件号 PART No.	名称 DESCRIPTION	数量 Q'TY	附注 REMARKS
1	CW6163C-06-014	堵 RING	1	
2	CW6163C-06-141A	手 轮 HAND WHEEL	1	
3	CW6163C-06-015	齿 轮 GEAR	1	
4	CW6163C-06-016A	结 合 子 COUPLING	1	
5	CW6163C-06-017A	齿 轮 GEAR	2	
6	CW6163C-06-018	轴 SHAFT	1	
7	CW6163C-06-119	法 兰 盘 FLANGE	1	
8	JB/GQ0453	内 隔 套 CONE SPACER 30X16	1	
9	GB71	螺 钉 SCREW M6X12	2	
10	GB72	螺 钉 SCREW M6X20	1	
11	GB1096	平 键 FLAT KEY 6X6X28	1	
12	GB1096	平 键 FLAT KEY 8X7X20	1	
13	GB893.1	弹性挡圈 SNAP RING 55	2	
14	205	轴 承 BEARING 25X52X15	1	
15	106	轴 承 BEARING 30X55X13	1	
16	7000106	轴 承 BEARING 30X55X9	4	
17	GB9877.1	密 封 圈 SEAL RING B-25X47X7	1	

CW6163C

Purchase Parts



图06-04 溜板箱  
FIG06-04 APRON

## Purchase Parts

CW6163C

部别 06  
GROUP  
插图号 06-04  
FIG No.

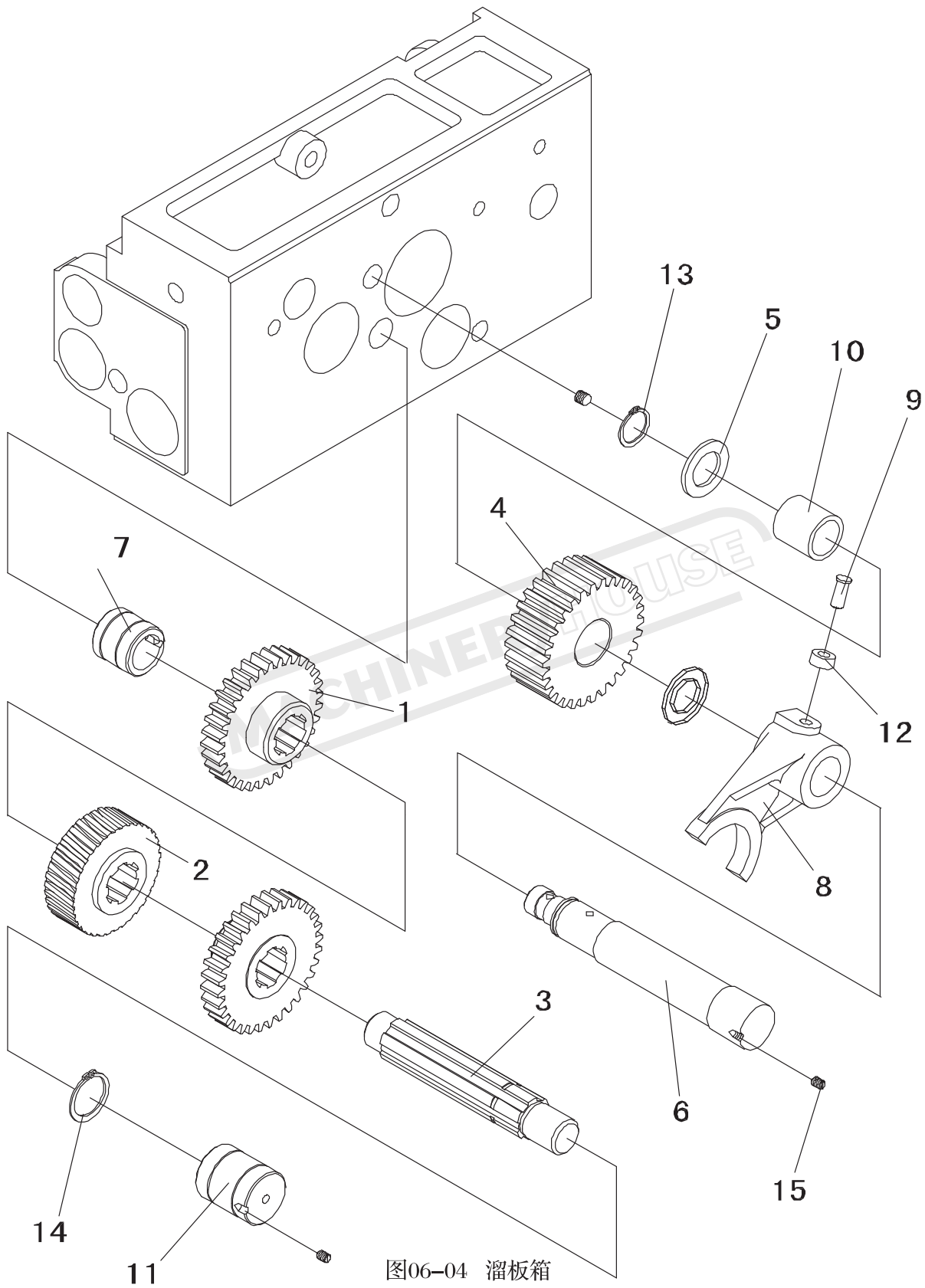
溜板箱  
APRON

图上序号 POSITION No.	件号 PART No.	名称 DESCRIPTION	数量 Q'TY	附注 REMARKS
1	CW6163C-06-019	齿 轮 GEAR	2	
2	CW6163C-06-020	蜗 轮 WORM	1	
3	CW6163C-06-021	轴 SPLINE	1	
4	CW6163C-06-023	齿 轮 GEAR	1	
5	CW6163C-06-024	垫 WASHER	2	
6	CW6163C-06-080	轴 SHAFT	1	
7	CW6163C-06-042	套 BUSH	1	
8	CW6163C-06-087	拨 叉 SHIFTING FORK	1	
9	CW6163C-06-058	销 子 PIN	1	
10	JB/GQ0452	轴 套 SPACER 32X32	1	
11	CW6163C-06-041	套 SLEEVE	1	
12	JB/GQ0488	滑 块 SPACER	1	
13	GB894.1	弹性挡圈 SNAP RING 25	1	
14	GB894.1	弹性挡圈 SNAP RING 30	1	
15	GB71	螺 钉 SCREW M6X12	3	
16	GB71	螺 钉 SCREW M8X16	1	



CW6163C

Purchase Parts



图06-05 溜板箱  
FIG06-05 APRON

## Purchase Parts

CW6163C

部别 06  
GROUP  
插图号 06-05  
FIG No.

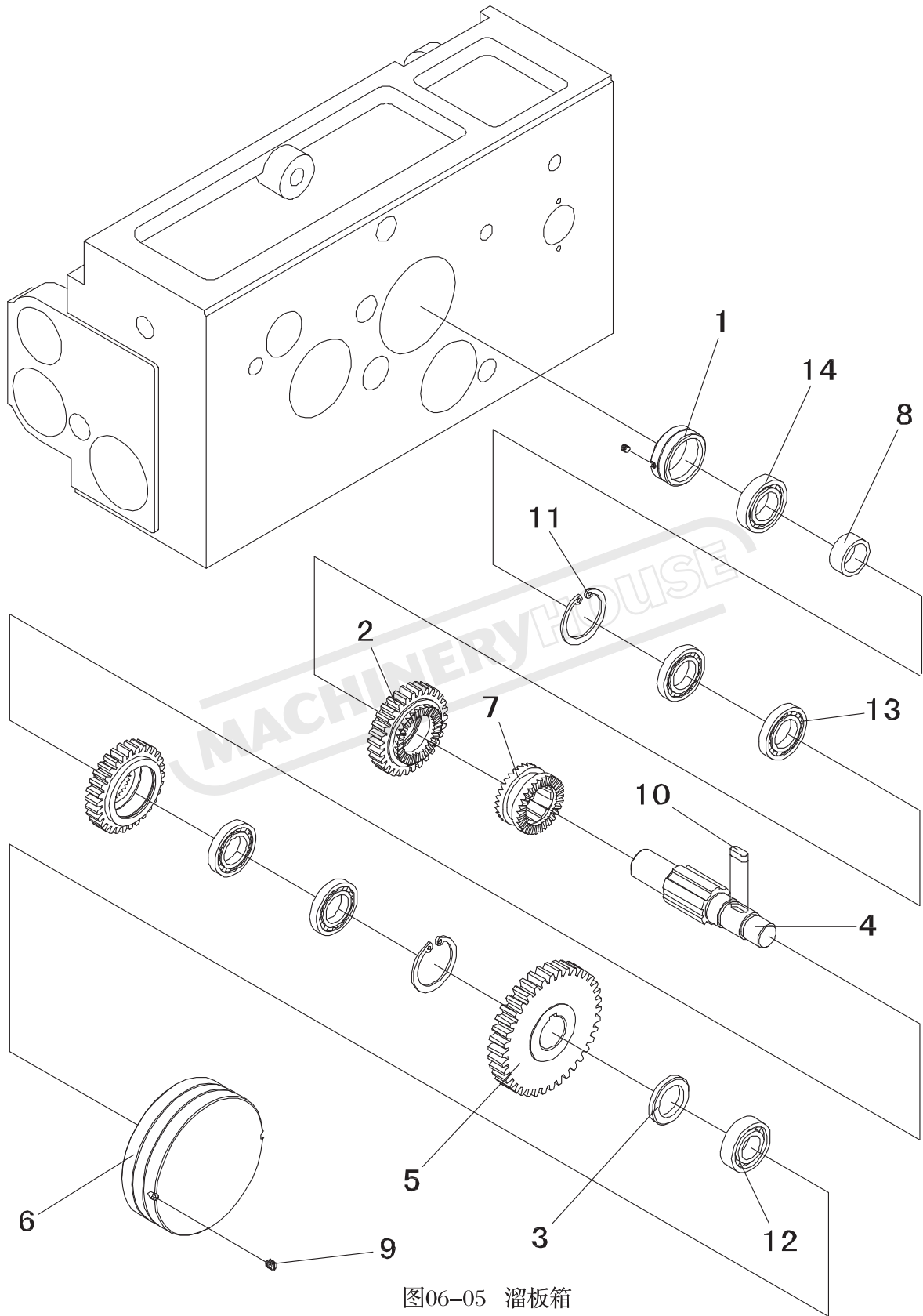
溜板箱  
APRON

图上序号 POSITION No.	件号 PART No.	名称 DESCRIPTION	数量 Q'TY	附注 REMARKS
1	CW6163C-06-014	堵 SPACER	1	
2	CW6163C-06-024	齿 轮 GEAR	2	
3	CW6163C-06-022	垫 WASHER	1	
4	CW6163C-06-027A	X轴 SHAFT	1	
5	CW6163C-06-028	齿 轮 GEAR	1	
6	CW6163C-06-040	法 兰 盘 FLANGE	1	
7	CW6163C-06-016A	结 合 子 COUPLING	1	
8	JB/GQ0453	内 隔 套 CONE SPACER 30X16	1	
9	GB71	螺 钉 SCREW M6X8	2	
10	GB1096	平 键 FLAT KEY 8X7X20	1	
11	GB893.1	弹性挡圈 SNAP RING 55	2	
12	205	轴 承 BEARING 25X52X15	1	
13	7000106	轴 承 BEARING 30X55X9	4	
14	106	轴 承 BEARING 30X55X13	1	
15	GB71	螺 钉 SCREW M6X12	2	

CW6163C

Purchase Parts



图06-06 溜板箱  
FIG06-06 APRON

## Purchase Parts

CW6163C

部别 06  
GROUP  
插图号 06-06  
FIG No.

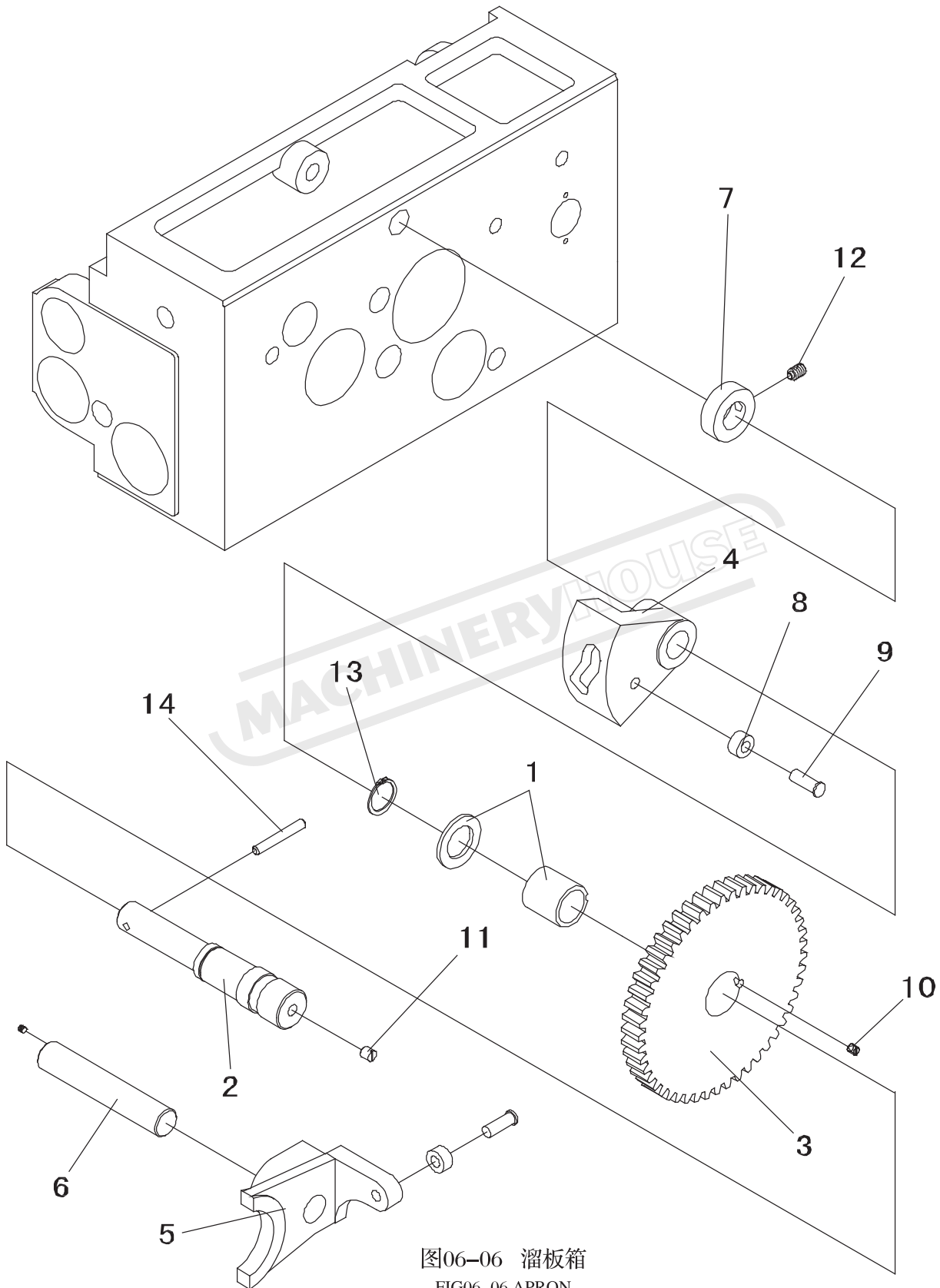
溜板箱  
APRON

图上序号 POSITION No.	件号 PART No.	名称 DESCRIPTION	数量 Q'TY	附注 REMARKS
1	CW6163C-06-024	垫 WASHER	1	
2	CW6163C-06-029A	轴 SHAFT	1	
3	CW6163C-06-030	齿 轮 GEAR	1	
4	CW6163C-06-088A	凸 轮 CAM	1	
5	CW6163C-06-081	拨 叉 SHIFTING FORK	1	
6	CW6163C-06-080	轴 ROD	1	
7	CW6163C-06-146A	套 SPACER	1	
8	JB/GQ0488	滑 块 SLIDE BLOCK	1	
9	CW6163C-06-057	销 子 PIN	2	
10	GB71	螺 钉 SCREW M6X8	2	
11	GB71	螺 钉 SCREW M8X16	1	
12	GB71	螺 钉 SCREW M8X10	1	
13	GB894.1	弹性挡圈 SNAP RING 25	1	
14	GB118	圆 锥 销 ROUND TAPER PIN A-6X45	1	
15	JB/GQ0452	轴 套 SPACER	1	

**CW6163C**

**Purchase Parts**



图06-07 溜板箱  
FIG06-07 APRON

## Purchase Parts

CW6163C

部别 06  
GROUP  
插图号 06-07  
FIG No.

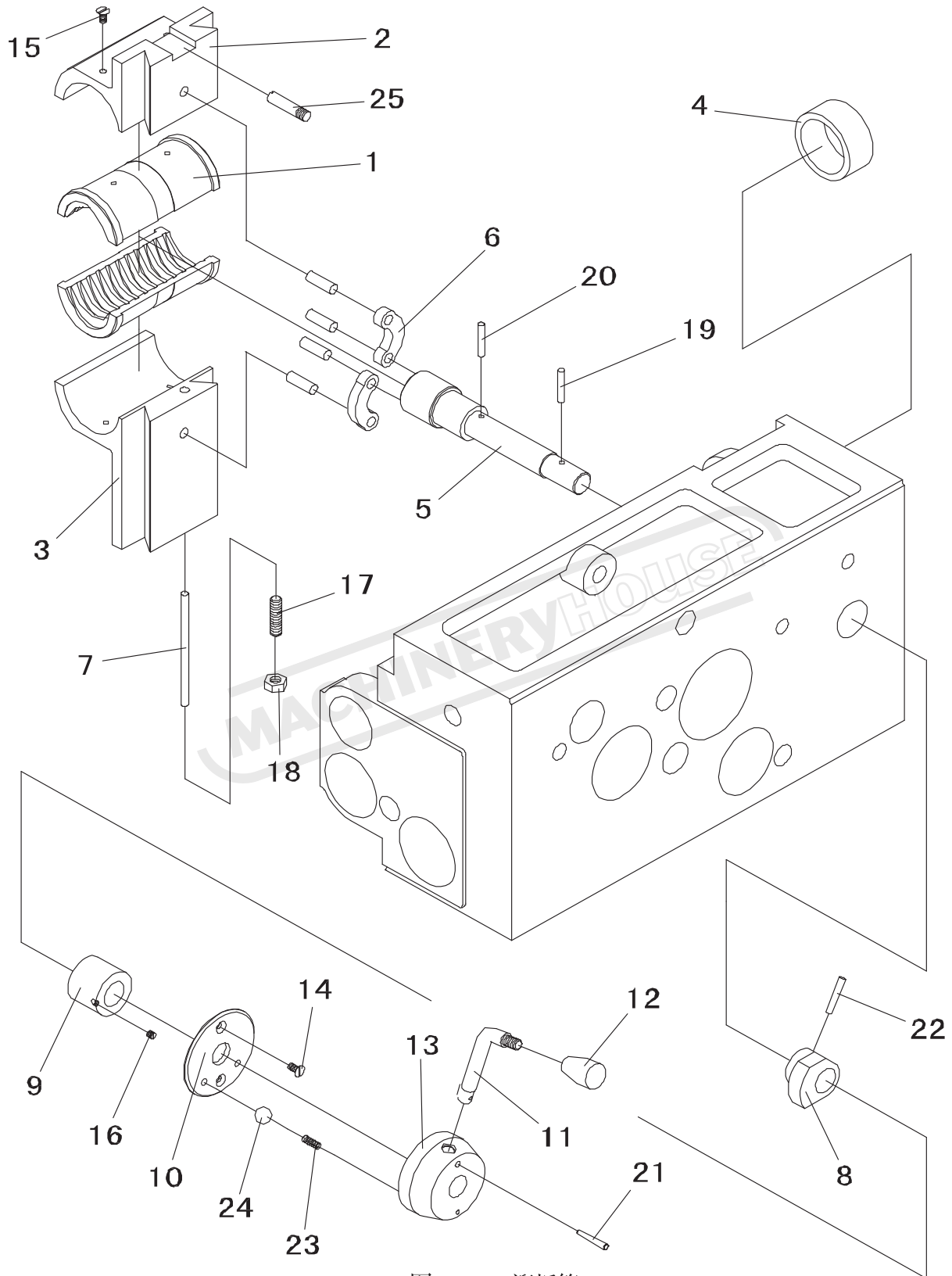
溜板箱  
APRON

图上序号 POSITION No.	件号 PART No.	名称 DESCRIPTION	数量 Q'TY	附注 REMARKS
1	CW6163C-06-031	开合螺母 HALF NUT	2	
2	CW6163C-06-032	开合螺母上体 UPPER HALF NUT SUPPORT	1	
3	CW6163C-06-033	开合螺母下体 LOWER HALF NUT SUPPORT	1	
4	CW6163C-06-035	套 SPACER	1	
5	CW6163C-06-122	轴 SHAFT	1	
6	CW6163C-06-135	连杆 CONNECTING ROD	2	
7	CW6163C-06-123	销子 PIN	1	
8	CW6163C-06-039	凸块 CONVEX BLOCK	1	
9	CW6163C-06-120	套 BUSH	1	
10	CW6163C-06-145	定位垫圈 LOCATION PAD	1	
11	CW6163C-06-129	手柄杆 SHANK ROD	1	
12	CW6163C-02-182	手柄 HANDLE	1	
13	QJ/D2 06.06.2/31	手柄座 HOUSING 铬B-12X22	1	
14	GB68	螺钉 SCREW M6X12	6	
15	GB71	螺钉 SCREW M6X8	1	
16	GB71	螺钉 SCREW M10X40	1	
17	GB6172	螺母 NUT M10	1	
18	GB117	圆锥销 ROUND TAPER PIN A-6X80	1	
19	GB117	圆锥销 ROUND TAPER PIN A-6X35	1	
20	GB117	圆锥销 ROUND TAPER PIN 4X35	1	
21	GB2089	弹簧 SPRING 1.2X7X25	1	
22	GB308	钢球 STEEL BALL $\phi$ 8G200b	1	
23	GB878	圆柱销 CYLINDRICAL PIN 10X45	1	

CW6163C

Purchase Parts



图06-08 溜板箱

FIG06 08 APRON

## Purchase Parts

CW6163C

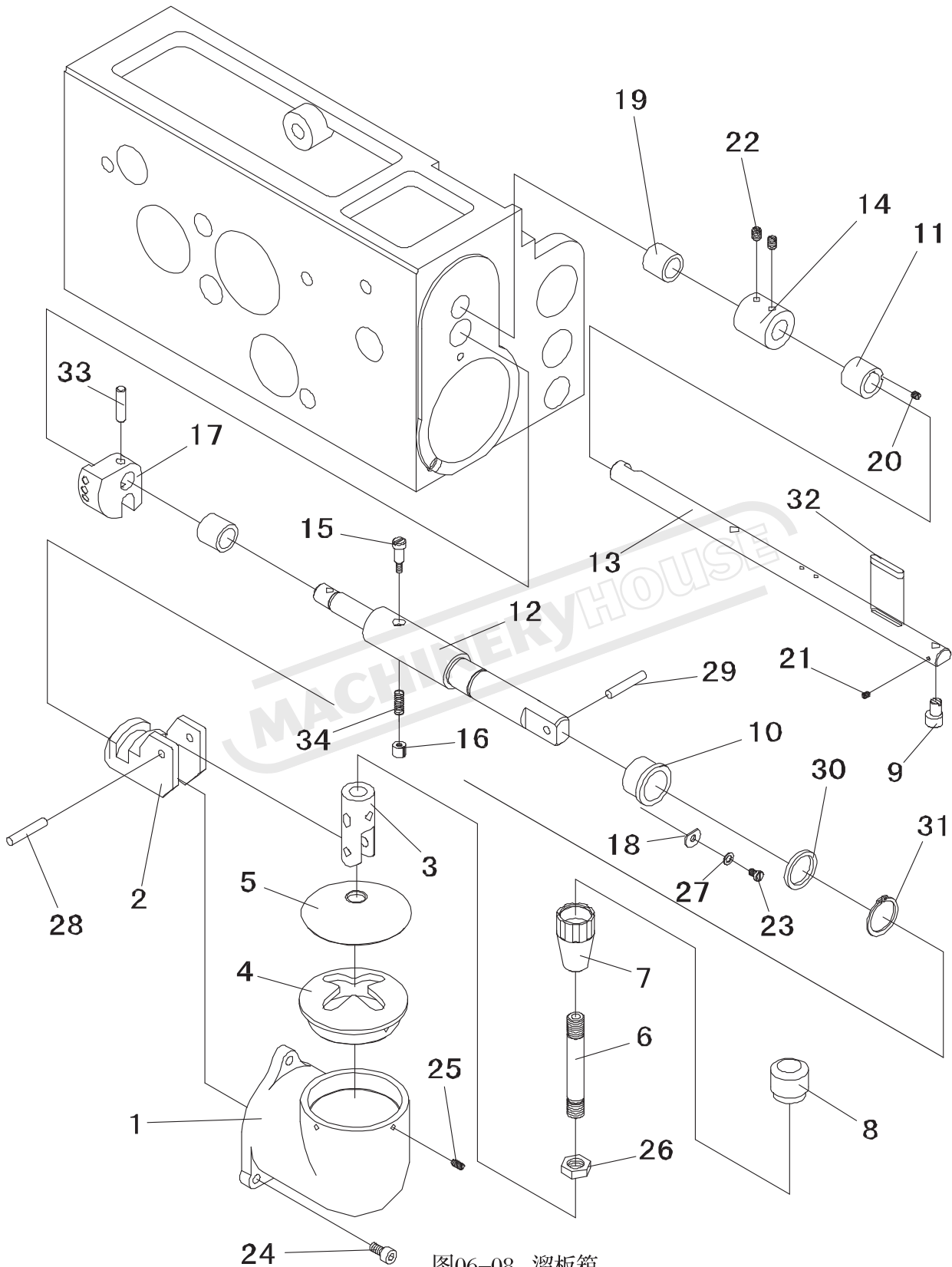
部别 06  
GROUP  
插图号 06-08  
FIG No.

溜板箱  
APRON

图上序号 POSITION No.	件号 PART No.	名称 DESCRIPTION	数量 Q'TY	附注 REMARKS
1	CW6163C-06-060	帽 HOUSING	1	
2	CW6163C-06-061	手柄座 SHIFTING FORK	1	
3	CW6163C-06-063	手柄座 SHIFTING FORK	1	
4	CW6163C-06-064	十字盖 CROSS COVER	1	
5	CW6163C-06-065	手柄盖 HANDLE COVER	1	
6	CW6163C-06-066	手柄杆 SHANK ROD	1	
7	CW6163C-06-067	手柄 HANDLE CAP	1	
8	CW6163C-06-068	手柄 NUT	1	
9	CW6163C-06-069	偏心销 ECCENTRIC PLUG	1	
10	CW6163C-06-070	套 SPACER	1	
11	CW6163C-06-071	套 SPACER	1	
12	CW6163C-06-073	轴 SHAFT	1	
13	CW6163C-06-072	轴 SHAFT	1	
14	CW6163C-06-074	联锁套 COUPLING SLEEVE	1	
15	CW6163C-06-075	螺钉 SCREW	1	
16	CW6163C-06-076	螺帽 NUT	1	
17	CW6163C-06-077	拨块 SHIFTING FORK	1	
18	CW6163C-06-082	垫 WASHER	1	
19	JB/GQ0452	轴套 SPACER	2	
20	GB71	螺钉 SCREW M6X12	1	
21	GB71	螺钉 SCREW M5X8	1	
22	GB72	螺钉 SCREW M8X12	1	
23	GB65	螺钉 SCREW M6X12	1	
24	GB70	螺钉 SCREW M8X16	1	
25	GB72	螺钉 SCREW M6X12	1	
26	GB6173	螺母 NUT M16X1.5	1	
27	GB93	垫圈 WASHER 6	1	
28	GB119	圆柱销 CYLINDRICAL PIN A-8X45	1	
29	GB119	圆柱销 CYLINDRICAL PIN A-10X24	1	
30	JB/GQ0453	内隔套 CONE SPACER 30X4	1	
31	GB894.1	弹性挡圈 SNAP RING 30	1	
32	GB1096	平键 FLAT KEY 6X6X40	1	
33	GB118	圆锥销 ROUND TAPER PIN A-8X35	1	
34	GB2089	弹簧 SPRING 0.8X9X25	1	



CW6163C

Purchase Parts



图06-09 溜板箱

FIG06-09 APRON

## Purchase Parts

CW6163C

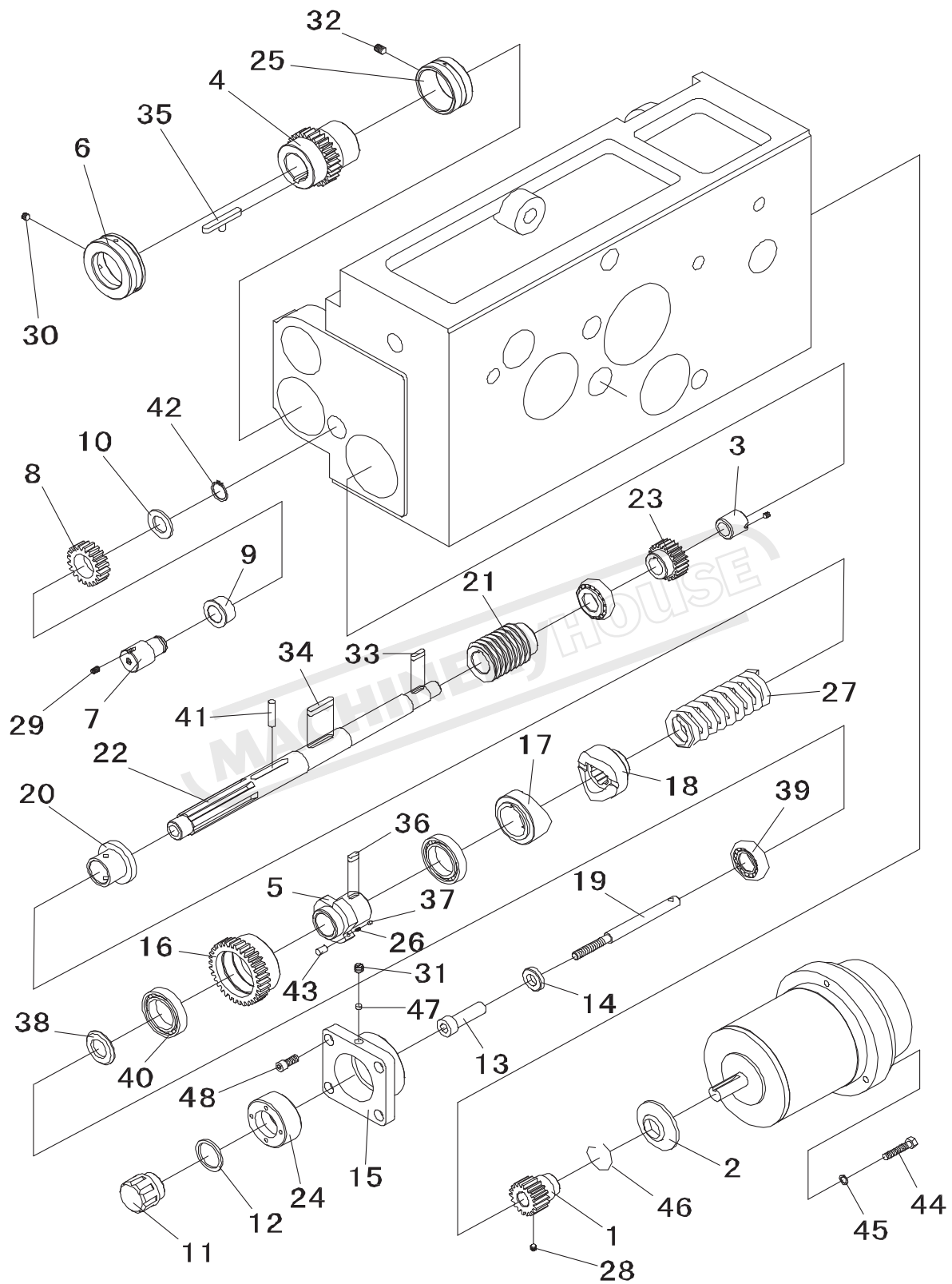
部别 06  
GROUP  
插图号 06-09  
FIG No.

溜板箱  
APRON

图上序号 POSITION No.	件号 PART No.	名称 DESCRIPTION	数量 Q'TY	附注 REMARKS
1	CW6163C-06-091	齿 轮 GEAR	1	
2	CW6163C-06-092	密封垫 SEALING WASHER	1	
3	CW6163C-06-093	套 SPACER	1	
4	CW6163C-06-094	齿 轮 GEAR	1	
5	CW6163C-06-096	星形体 STAR	1	
6	CW6163C-06-098	套 BUSH	1	
7	CW6163C-06-100	轴 SHAFT	1	
8	CW6163C-06-101	齿 轮 GEAR	1	
9	CW6163C-06-102	套 SLEEVE	1	
10	CW6163C-06-103	垫 WASHER	1	
11	CW6163C-06-104	盖 CAP	1	
12	CW6163C-06-105	垫 WASHER	1	
13	CW6163C-06-106	螺 套 NUT	1	
14	CW6163C-06-107	垫 WASHER	1	
15	CW6163C-06-108	法兰盘 FLANGE	1	
16	CW6163C-06-110	齿 轮 GEAR	1	
17	CW6163C-06-111	结合子 COUPLING	1	
18	CW6163C-06-112	结合子 COUPLING	1	
19	CW6163C-06-113	拉 杆 LINK	1	
20	CW6163C-06-114	导 套 GUIDING SLEEVE	1	
21	CW6163C-06-115	蜗 杆 WORM	1	
22	CW6163C-06-116	轴 SPLINE	1	
23	CW6163C-06-117	齿 轮 GEAR	1	
24	CW6163C-06-140	螺 母 NUT	1	
25	CW6163C-06-147	轴 套 SHAFT SLEEVE	1	
26	GB2089	弹 簧 SPRING 0.5X3X11	3	
27	GB2089	弹 簧 SPRING 8X50X95	1	
28	GB71	螺 钉 SCREW M6X10	1	

CW6163C

Purchase Parts

部别 06  
GROUP  
插图号 06-09  
FIG No.

## 溜板箱 APRON

图上序号 POSITION No.	件号 PART No.	名称 DESCRIPTION	数量 Q'TY	附注 REMARKS
29	GB71	螺 钉 SCREW M6X12	1	
30	GB71	螺 钉 SCREW M8X10	1	
31	GB71	螺 钉 SCREW M10X12	1	
32	GB71	螺 钉 SCREW M8X16	1	
33	GB1096	平 键 FLAT KEY 6X6X20	1	
34	GB1096	平 键 FLAT KEY 8X7X40	1	
35	QJ/D2 06.01.6	陷入平键 SET FLAT KEY B-8h9X7X60	1	
36	GB1096	平 键 FLAT KEY 6X6X16	1	
37	C-31-1-35	销 PIN	3	
38	CW6163C-06-124	隔 套 SPACER	1	
39	7205	轴 承 BEARING 25X52X16.5	2	
40	1000908	轴 承 BEARING 40X62X12	2	
41	GB119	圆 柱 销 CYLINDRICAL PIN A-8X35	1	
42	GB894.1	弹性挡圈 SNAP RING 22	1	
43	C31-1-34	滚 子 ROLLER	1	
44	GB70	螺 钉 SCREW M6X12	3	
45	GB93	垫 圈 WASHER 8	3	
46	GB921	钢丝锁圈 CLAMPING RING 30	1	
47	QJ/D2 06.01.4	垫 块 BLOCK 7X4	1	
48	GB70	螺 钉 SCREW M8X20	4	

图06-09 溜板箱  
FIG06-09 APRON

## Purchase Parts

CW6163C



图06-10 溜板箱  
FIG06-10 APRON

CW6163C

Purchase Parts

部别 06  
GROUP  
插图号 06-10  
FIG No.

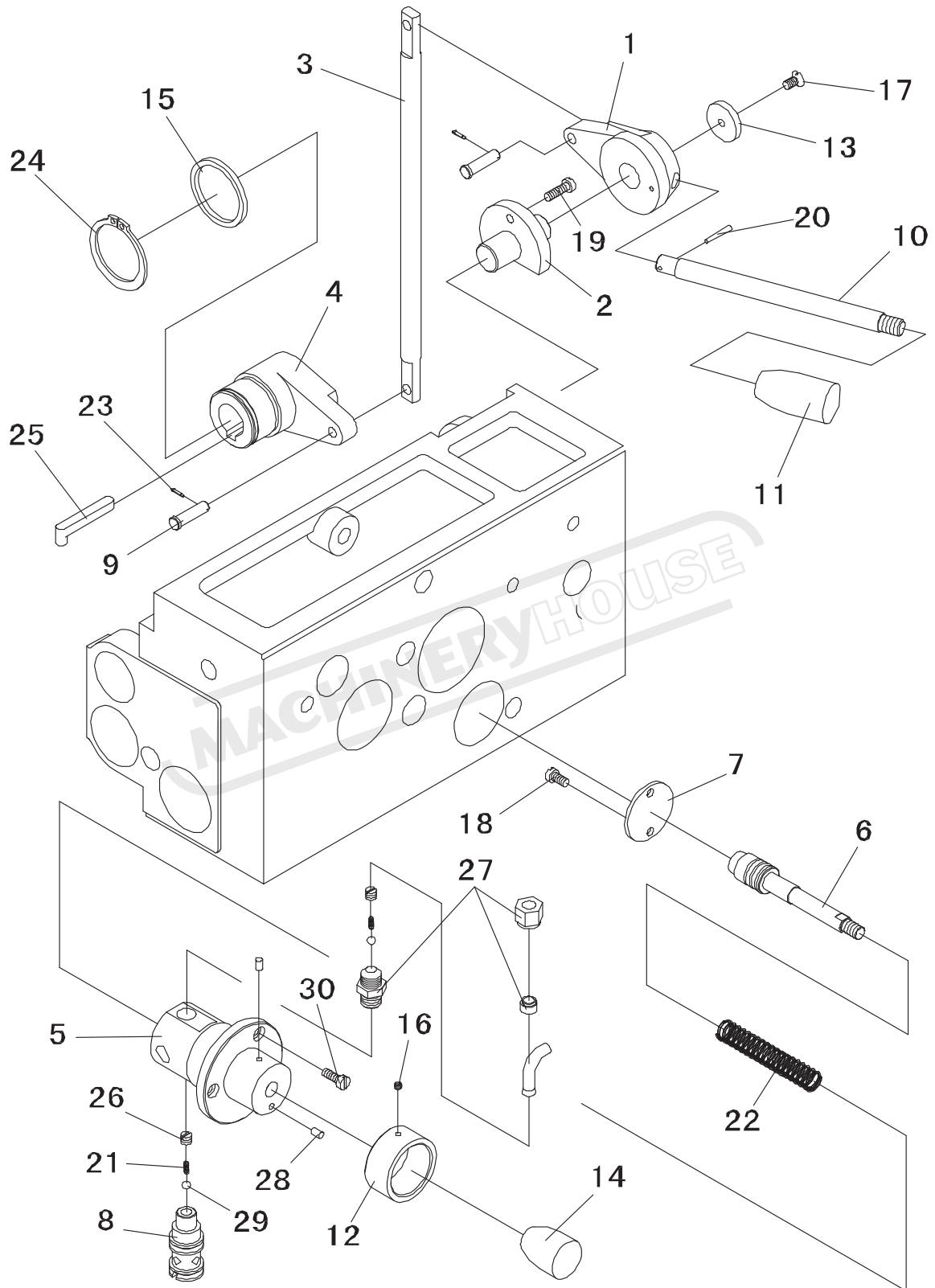
# 溜板箱

## APRON

图上序号 POSITION No.	件号 PART No.	名称 DESCRIPTION	数量 Q'TY	附注 REMARKS
1	CW6163C-06-048	手柄座 HOUSING	1	
2	CW6163C-06-049	手柄座 HOUSING	1	
3	CW6163C-06-050	连杆 CONNECTING ROD	1	
4	CW6163C-06-051	杠杆 SHIFTING BAR	1	
5	CW6163C-06-052	油泵体 PUMP BODY	1	
6	CW6163C-06-053	活塞 PISTON	1	
7	CW6163C-06-054	油泵盖 COVER PLATE FOR OIL PUMP	1	
8	CW6163C-06-055	滤油器 OIL-FILTER	1	
9	CW6163C-06-121	销 PINS	2	
10	CW6163C-06-128	手柄 HANDLE ROD	1	
11	CW6163C-06-143	手柄 HANDLE CAP	1	
12	CW6163C-06-144	套 SPACER	1	
13	CW6163C-02-119	垫 PLUG	1	
14	CW6163C-02-182	手柄 HANDLE CAP	1	
15	JB/GQ0453	内隔套 CONE SPACER 45X4	1	
16	GB71	螺钉 SCREW M5X6	1	
17	GB68	螺钉 SCREW M6X12	1	
18	GB65	螺钉 SCREW M6X12	2	
19	GB68	螺钉 SCREW M6X20	1	
20	GB117	圆锥销 ROUND TAPER PIN A-3X24	1	
21	GB2089	弹簧 SPRING 0.5X3.5X17	2	
22	GB2089	弹簧 SPRING 1.6X16X95	1	
23	GB91	开口销 SPLIT PIN 2X16	2	
24	GB894.1	弹性挡圈 SNAP RING 45	1	
25	QJ/D2 06.01.6	陷入平键 SET FLAT KEY 8h9X7X55	1	
26	JB/GQ0431/32	调节螺钉 ADJUSTING SCREW 8	2	
27	JB/GQ0431	安全阀 SAFETY VALVE	1	
28	GB119	圆柱销 CYLINDRICAL PIN A-5X8	2	
29	GB308	钢球 STEEL BALL $\phi$ 5G200b	2	
30	GB65	螺钉 SCREW M6X16	3	
31		铜网 COPPER NET 16/cm 30X100	1	

## Purchase Parts

CW6163C



图07-01 进给箱  
FIG07-01 GEARBOX

CW6163C

Purchase Parts

部别 07  
GROUP  
插图号 07-01  
FIG No.

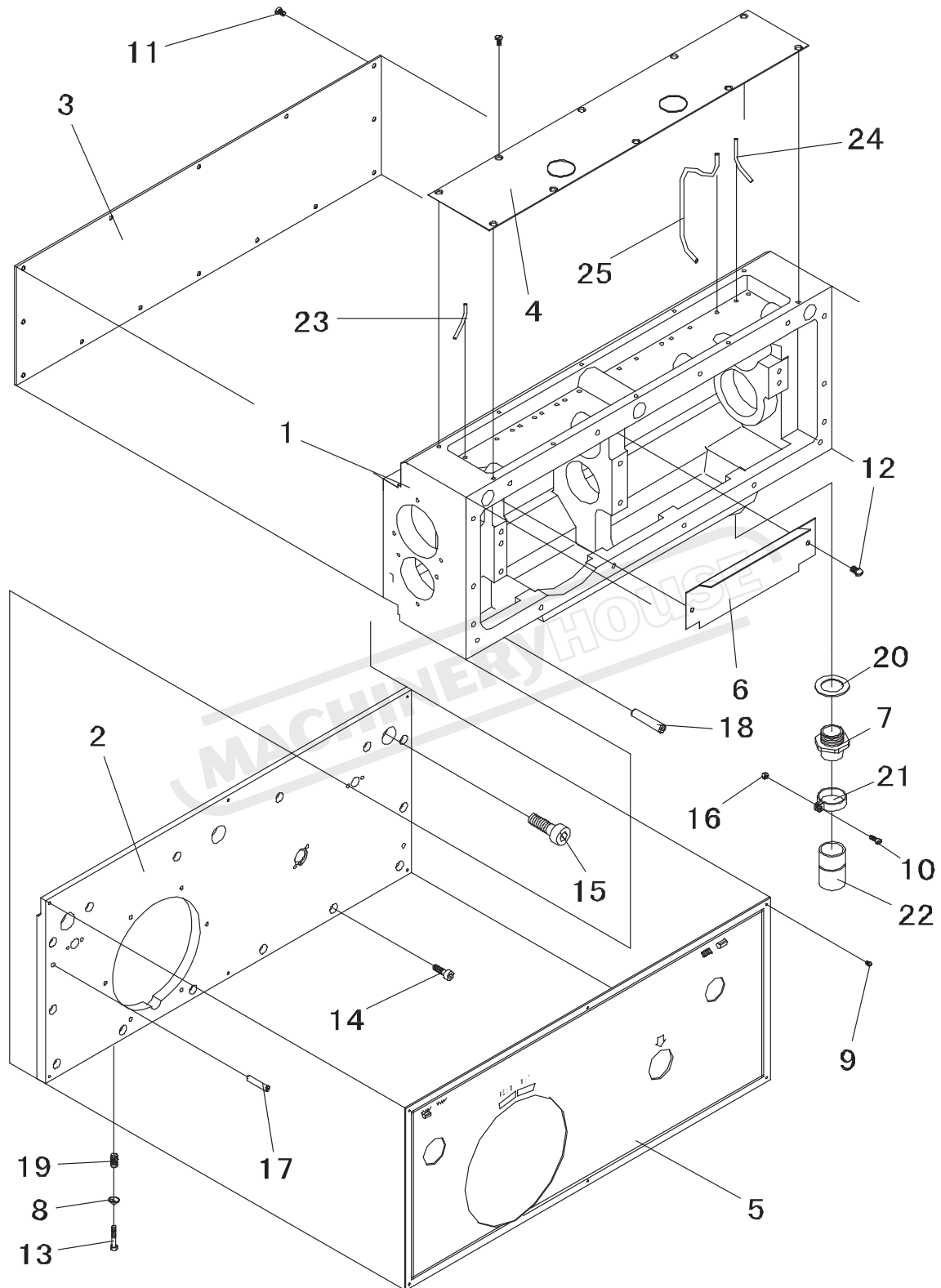
# 进给箱

## GEARBOX

图上序号 POSITION No.	件号 PART No.	名称 DESCRIPTION	数量 Q'TY	附注 REMARKS
1	CW6163C-07-011	进给箱体 GEARBOX CASTING	1	
2	CW6163C-07-012	前 盖 FRONT COVER	1	
3	CW6163C-07-059	后 盖 板 REAR COVER	1	
4	CW6163C-07-106	上 盖 UPPER COVER	1	
5	CW6163C-07-109A	标 牌 MARK PLATE	1	
6	CW6163C-07-111	挡 板 BAFFLE	1	
7	CW6163C-07-090A	软管接头 HOSE CONNECTOR	1	
8	CW6163C-05-046	垫 GASKET	2	
9	GB67	螺 钉 SCREW M3X6	6	
10	GB65	螺 钉 SCREW M6X12	1	
11	GB68	螺 钉 SCREW M6X12	14	
12	GB67	螺 钉 SCREW M6X8	2	
13	GB65	螺 钉 SCREW M6X35	2	
14	GB70	螺 钉 SCREW M8X20	19	
15	GB70	螺 钉 SCREW M16X50	5	
16	GB41	螺 母 NUT M6	1	
17	GB118	圆 锥 销 ROUND TAPER PIN A-8X40	2	
18	GB118	圆 锥 销 ROUND TAPER PIN A-12X60	2	
19	GB2089	弹 簧 SPRING 1X10X19	2	
20	JB/GQ0332	垫 圈 WASHER 33	1	
21	D <sub>2</sub> J69-1	锁 紧 圈 LOCKING RING	1	
22	HG4-761-74	耐油胶管 OIL RESISTANCE TUBE 32X220	1	外径 φ 36mm OUTSIDE DIAMETER
23	GB1527	铜 管 COPPER PIPE φ 6X1X120M	1	
24	SG79	软 塑 管 PLASTIC SOFT PIPE 流 φ 4X80	1	
25	GB1527	铜 管 COPPER PIPE φ 6X1X230M	1	

## Purchase Parts

CW6163C



图07-02 进给箱  
FIG07-02 GEARBOX



CW6163C

Purchase Parts

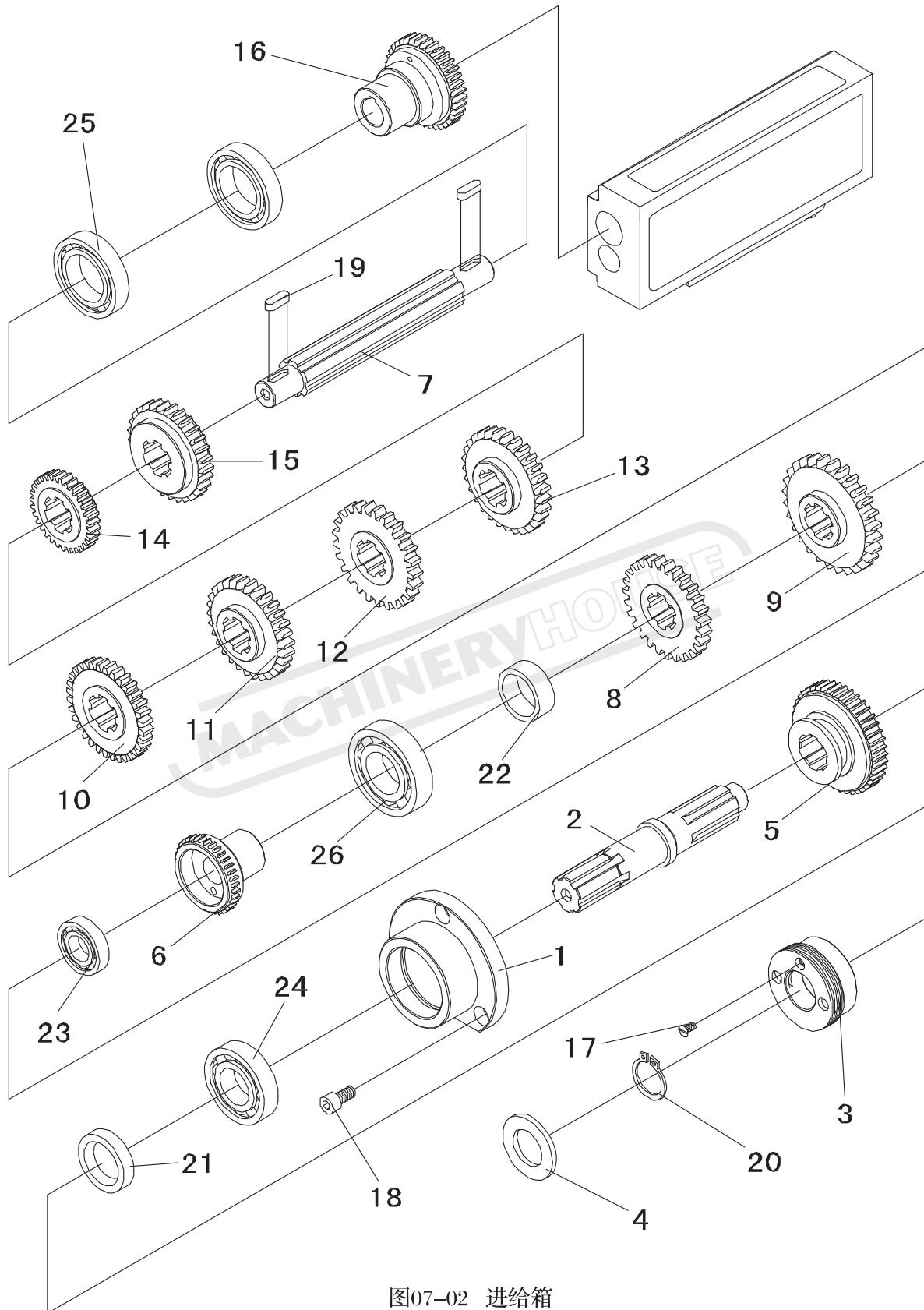
部别 07  
GROUP  
插图号 07-02  
FIG No.

# 进给箱

## GEARBOX

图上序号 POSITION No.	件号 PART No.	名称 DESCRIPTION	数量 Q'TY	附注 REMARKS
1	CW6163C-07-013	左端盖 LEFT END COVER	1	
2	CW6163C-07-014	I轴 I SHAFT	1	
3	CW6163C-07-016	圆螺母 ROUND NUT	1	
4	CW6163C-07-017	挡圈 WASHER	1	
5	CW6163C-07-018	齿轮 GEAR	1	
6	CW6163C-07-019	齿轮 GEAR	1	
7	CW6163C-07-020	II轴 II SHAFT	1	
8	CW6163C-07-021	齿轮 GEAR	1	
9	CW6163C-07-022	齿轮 GEAR	1	
10	CW6163C-07-023	齿轮 GEAR	1	
11	CW6163C-07-024	齿轮 GEAR	1	
12	CW6163C-07-025	齿轮 GEAR	1	
13	CW6163C-07-026	齿轮 GEAR	1	
14	CW6163C-07-027	齿轮 GEAR	1	
15	CW6163C-07-028	齿轮 GEAR	1	
16	CW6163C-07-029	齿轮 GEAR	1	
17	GB68	螺钉 SCREW M6X12	1	
18	GB70	螺钉 SCREW M10X20	3	
19	GB1096	平键 FLAT KEY 8X7X25	1	
20	GB894.1	弹性挡圈 SNAP RING 35	1	
21	GB9877.1	密封圈 SEAL RING B-35X55X8	1	
22	CW6163C-07-117	隔套 SPACER	1	
23	GB276-64	轴承 BEARING 205	1	
24	GB276-64	轴承 BEARING 207	1	
25	GB276-64	轴承 BEARING 109	2	
26	GB276-64	轴承 BEARING 208	1	

## Purchase Parts

CW6163C



图07-03 进给箱  
FIG07-03 GEARBOX

CW6163C

Purchase Parts

部别 07  
GROUP  
插图号 07-03  
FIG No.

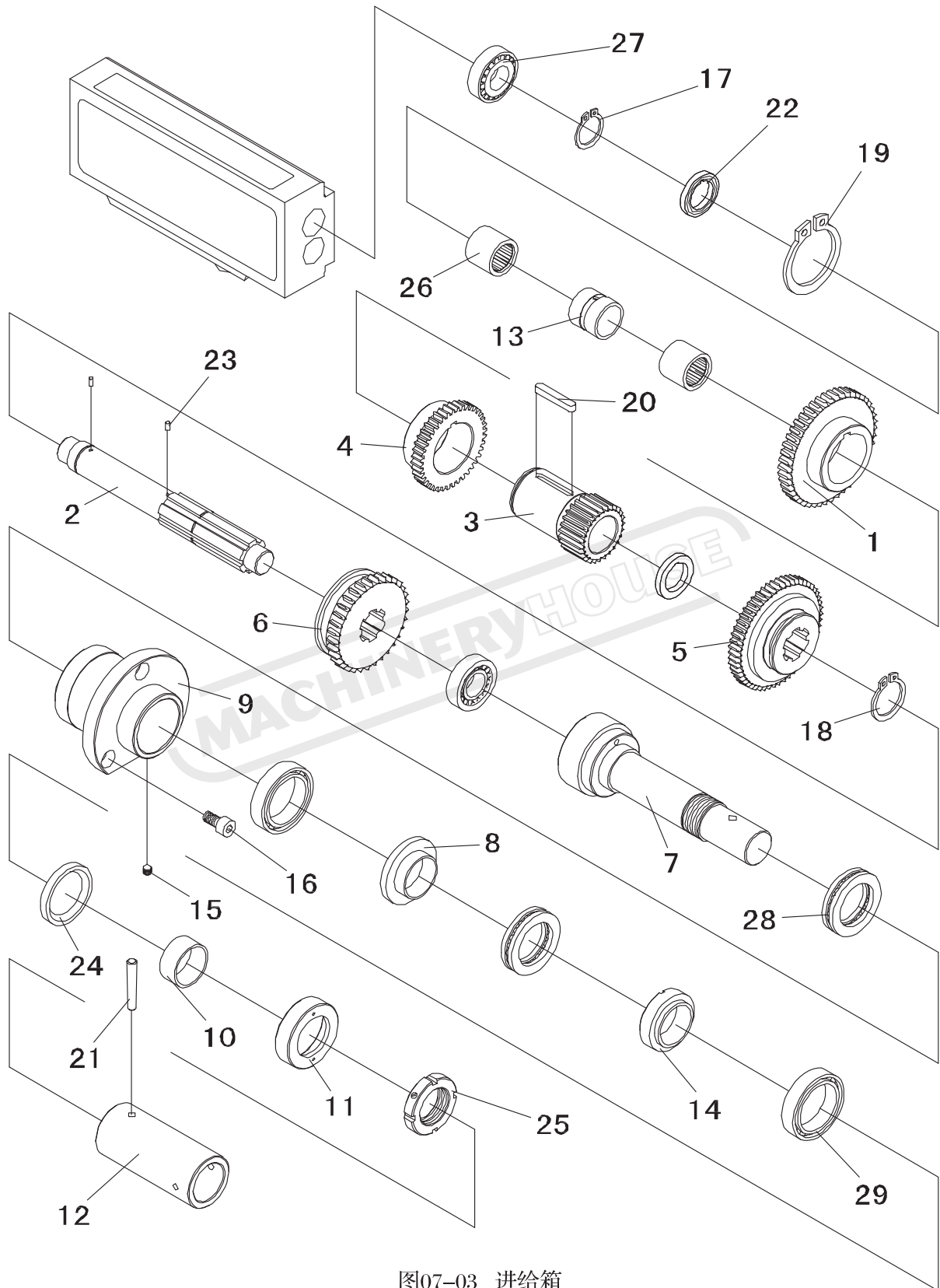
# 进给箱

## GEARBOX

图上序号 POSITION No.	件号 PART No.	名称 DESCRIPTION	数量 Q'TY	附注 REMARKS
1	CW6163C-07-015	齿 轮 GEAR	1	
2	CW6163C-07-030	V轴 V SHAFT	1	
3	CW6163C-07-031	齿 轮 GEAR	1	
4	CW6163C-07-032	齿 轮 GEAR	1	
5	CW6163C-07-033	齿 轮 GEAR	1	
6	CW6163C-07-034	齿 轮 GEAR	1	
7	CW6163C-07-035	VI轴 VI SHAFT	1	
8	CW6163C-07-036	环 BUSH	1	
9	CW6163C-07-037	套 SLEEVE	1	
10	CW6163C-07-038	套 SLEEVE	1	
11	CW6163C-07-039	挡 圈 SPACER	1	
12	CW6163C-07-040	丝杠接套 LEAD SCREW SLEEVE	1	
13	CW6163C-07-058	隔 套 SPACER	1	
14	CW6163C-07-108	垫 GASKET	1	
15	GB71	螺 钉 SCREW M6X12	1	
16	GB70	螺 钉 SCREW M10X20	3	
17	GB894.1	弹性挡圈 SNAP RING 30	1	
18	GB894.1	弹性挡圈 SNAP RING 35	1	
19	GB894.1	弹性挡圈 SNAP RING 50	1	
20	GB1096	平 键 FLAT KEY 8X7X50	1	
21	GB117	圆 锥 销 ROUND TAPER PIN A-8X55	2	
22	QJ/D2 06.01.1	挡 圈 SPACER 30	2	
23	GB119	圆 柱 销 CYLINDRICAL PIN A-4X8	2	
24	GB9877.1	密 封 圈 SEAL RING B-45X62X8	1	
25	J14-6	圆 螺 母 ROUND NUT M39X1.5	1	套 SET
26	GB289-64	轴 承 BEARING 943/30	2	
27	GB297-64	轴 承 BEARING 7205	2	
28	GB301-64	轴 承 BEARING D8109	2	
29	GB276-64	轴 承 BEARING D108	2	

## Purchase Parts

CW6163C



图07-04 进给箱  
FIG07-04 GEARBOX

CW6163C

Purchase Parts

部别 07  
GROUP  
插图号 07-04  
FIG No.

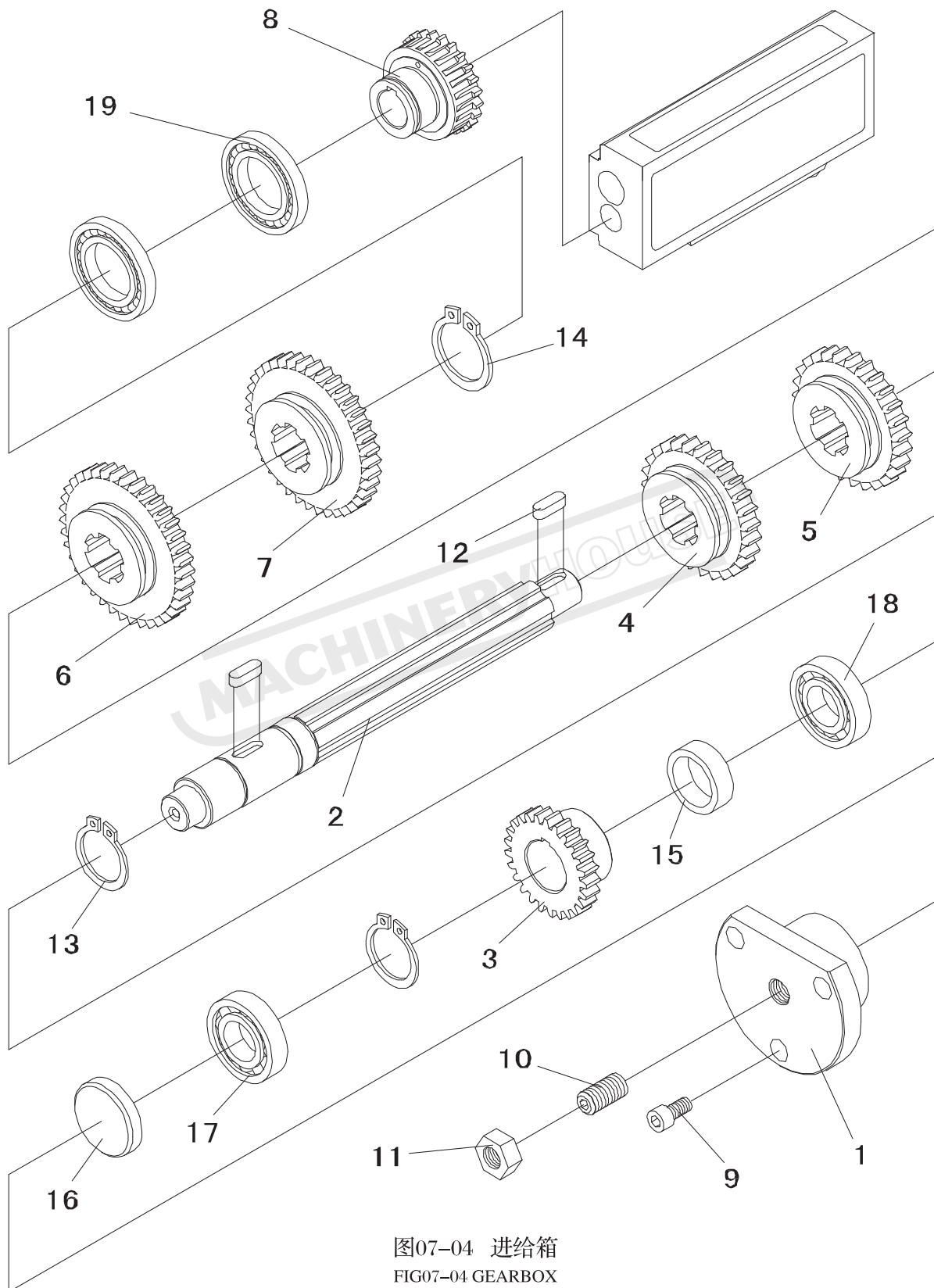
# 进给箱

## GEARBOX

图上序号 POSITION No.	件号 PART No.	名称 DESCRIPTION	数量 Q'TY	附注 REMARKS
1	CW6163C-07-041	盖 HOUSING	1	
2	CW6163C-07-042	III轴 III SPLINE	1	
3	CW6163C-07-043	齿 轮 GEAR	1	
4	CW6163C-07-044	齿 轮 GEAR	1	
5	CW6163C-07-045	齿 轮 GEAR	1	
6	CW6163C-07-046	齿 轮 GEAR	1	
7	CW6163C-07-047	齿 轮 GEAR	1	
8	CW6163C-07-048	齿 轮 GEAR	1	
9	GB70	螺 钉 SCREW M10X20	3	
10	GB78	螺 钉 SCREW M16X35	1	
11	GB6172	螺 母 NUT M16	1	
12	GB1096	平 键 FLAT KEY 8X7X25	2	
13	GB894.1	弹性挡圈 SNAP RING 35	2	
14	GB894.1	弹性挡圈 SNAP RING 40	1	
15	JB/GQ0453	隔 套 SPACER 35X14	1	
16	JB/GQ0464	顶 盖 CAP 52	1	
17	GB276-64	轴 承 BEARING 205	1	
18	GB276-64	轴 承 BEARING 107	1	
19	GB276-64	轴 承 BEARING 7000108	2	

## Purchase Parts

CW6163C



图07-05 进给箱  
FIG07-05 GEARBOX

CW6163C

Purchase Parts

部别 07  
GROUP  
插图号 07-05  
FIG No.

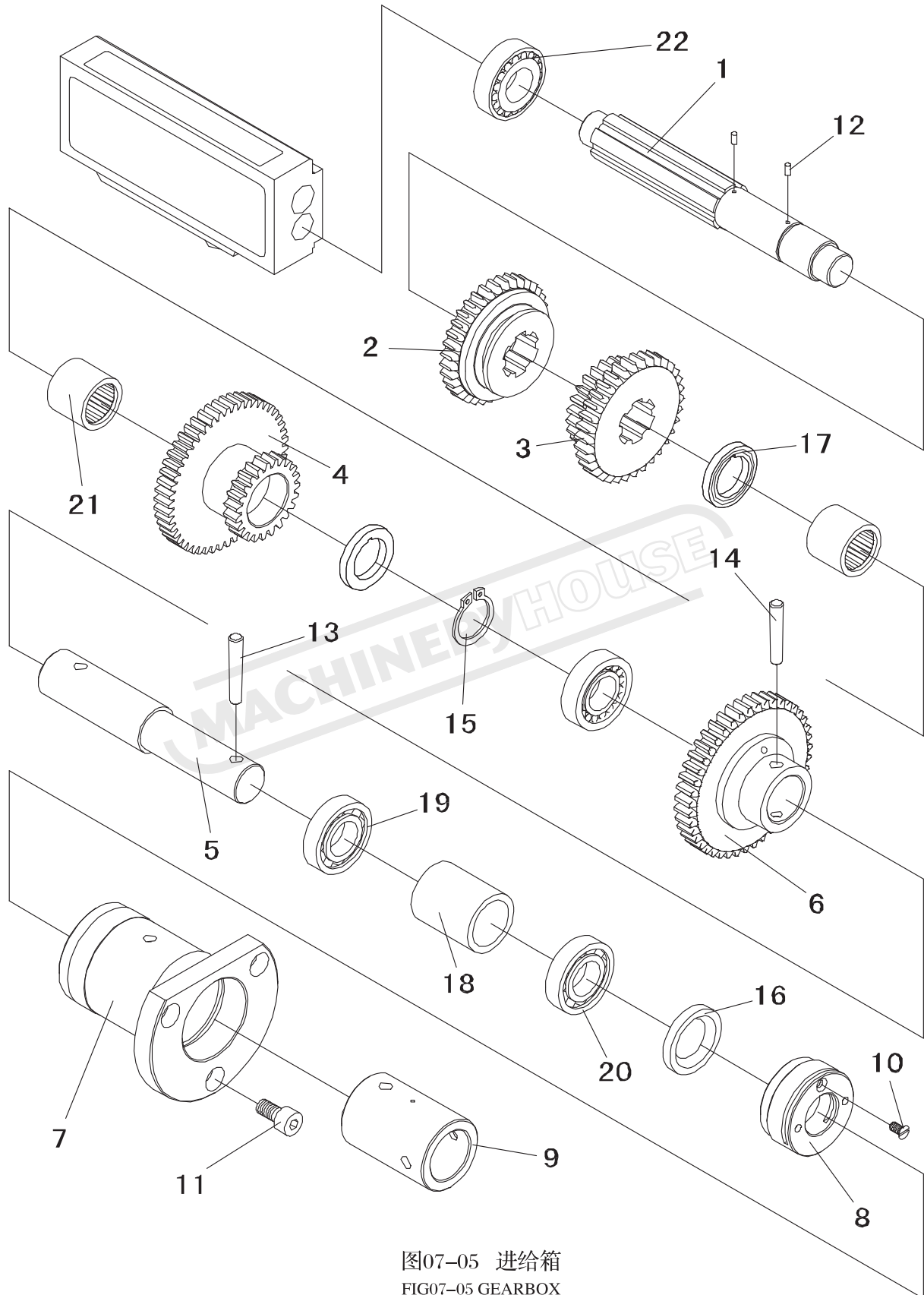
# 进给箱

## GEARBOX

图上序号 POSITION No.	件号 PART No.	名称 DESCRIPTION	数量 Q'TY	附注 REMARKS
1	CW6163C-07-049	IV轴 IV SHAFT	1	
2	CW6163C-07-050	齿 轮 GEAR	1	
3	CW6163C-07-051	齿 轮 GEAR	1	
4	CW6163C-07-052	齿 轮 GEAR	1	
5	CW6163C-07-053	VII轴 VII SHAFT	1	
6	CW6163C-07-054	齿 轮 GEAR	1	
7	CW6163C-07-055	轴 承 套 HOUSING	1	
8	CW6163C-07-056	圆 螺 母 ROUND NUT	1	
9	CW6163C-07-057	光杠接套 ROD SPLICING SLEEVE	1	
10	GB68	螺 钉 SCREW M6X12	1	
11	GB70	螺 钉 SCREW M10X20	3	
12	GB119	圆 柱 销 CYLINDRICAL PIN A-4X8	2	
13	GB117	圆 锥 销 TAPER PIN A-8X55	1	
14	GB117	圆 锥 销 TAPER PIN A-8X50	1	
15	GB894.1	弹性挡圈 SNAP RING 30	1	
16	GB9877.1	密 封 圈 SEAL RING B-30X50X7	1	
17	QJ/D2 06.01.1	挡 圈 SPACER 30	2	
18	JB/GQ0453	隔 套 SPACER 35X55	1	
19	GB276-64	轴 承 BEARING 107	1	
20	GB276-64	轴 承 BEARING 206	1	
21	GB289-64	轴 承 BEARING 943/30	2	
22	GB297-64	轴 承 BEARING 7205	2	

Purchase Parts

CW6163C



图07-06 进给箱  
FIG07-05 GEARBOX



CW6163C

Purchase Parts

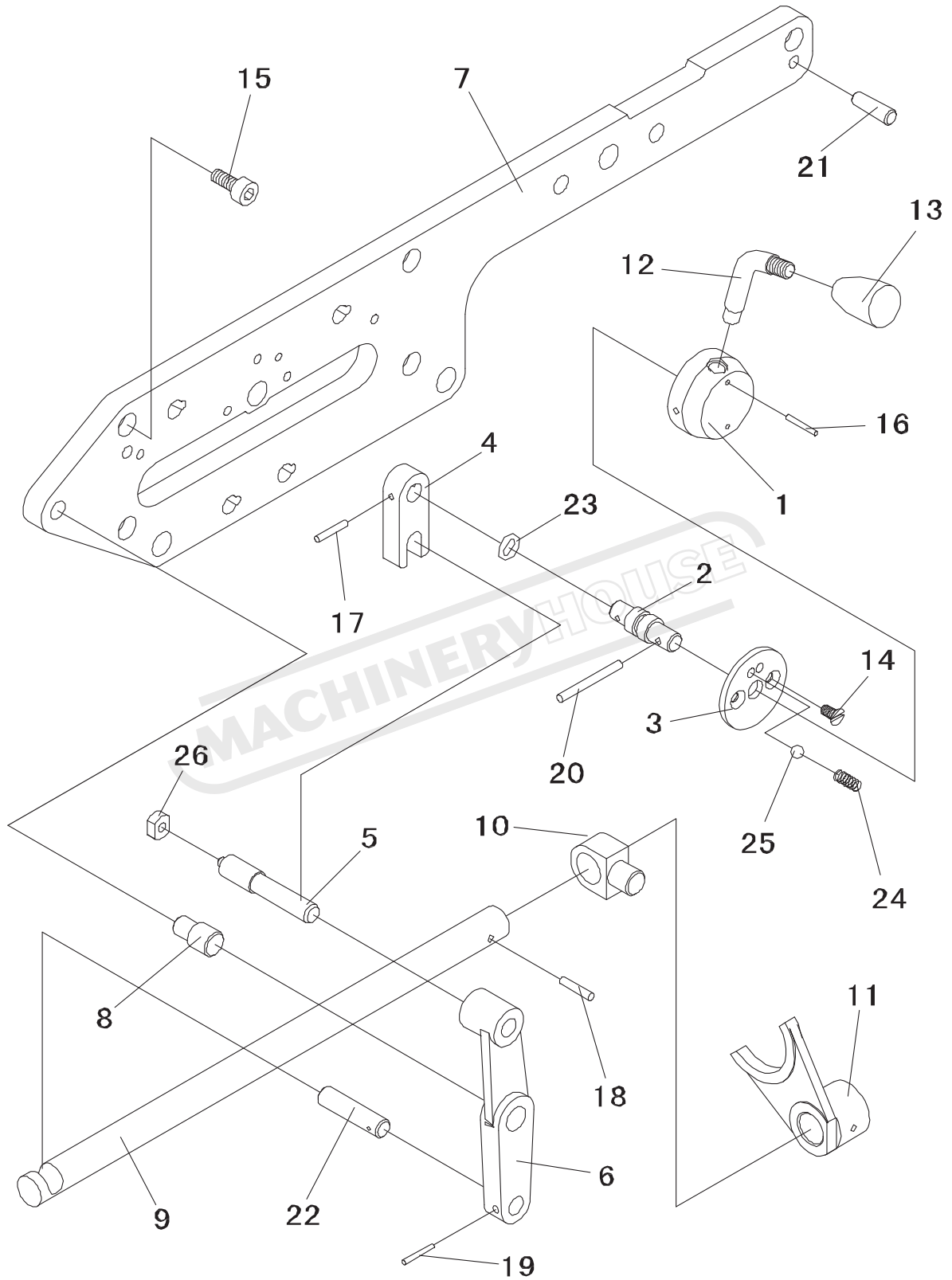
部别 07  
GROUP  
插图号 07-06  
FIG No.

# 进给箱

## GEARBOX

图上序号 POSITION No.	件号 PART No.	名称 DESCRIPTION	数量 Q'TY	附注 REMARKS
1	CW6163C-07-060	手柄座 HANDLE BLOCK	2	
2	CW6163C-07-061	轴 SHAFT	1	
3	CW6163C-07-062	定位垫 POSITIONING PAD	1	
4	CW6163C-07-063	拨 叉 SHIFTING FORK	1	
5	CW6163C-07-064	轴 SHAFT	1	
6	CW6163C-07-065	杠 杆 SHIFTING BAR	1	
7	CW6163C-07-066	操纵板 CONSOLE PANEL	1	
8	CW6163C-07-067	小 轴 SMALL SHAFT	1	
9	CW6163C-07-068	拉 杆 LINK	1	
10	CW6163C-07-088	支 架 SUPPORT	2	
11	CW6163C-07-089	拨 叉 SHIFTING FORK	1	
12	CW6163C-07-113	手柄杆 SHANK ROD	4	
13	CW6163C-02-182	手 柄 SLEEVE	6	
14	GB68	螺 钉 SCREW M6X12	4	
15	GB70	螺 钉 SCREW M8X20	5	
16	GB117	圆锥销 ROUND TAPER PIN A-3X20	4	
17	GB117	圆锥销 ROUND TAPER PIN A-4X24	1	
18	GB117	圆锥销 ROUND TAPER PIN A-5X35	1	
19	GB117	圆锥销 ROUND TAPER PIN A-5X24	1	
20	GB117	圆锥销 ROUND TAPER PIN A-5X50	2	
21	GB118	圆锥销 ROUND TAPER PIN A-8X30	2	
22	GB119	圆柱销 CYLINDRICAL PIN A-12X50	1	
23	GB3452.1	密封圈 SEAL RING 11.2X2.65	1	
24	GB2089	弹 簧 SPRING 1.2X7X16	2	
25	GB308	钢 球 STEEL BALL $\phi$ 8G200b	2	
26	Q99-1	滑 块 SHIFTING PAD B12	2	

Purchase Parts

CW6163C



图07-07 进给箱  
FIG07-07 GEARBOX

CW6163C

Purchase Parts

部别 07  
GROUP  
插图号 07-07  
FIG No.

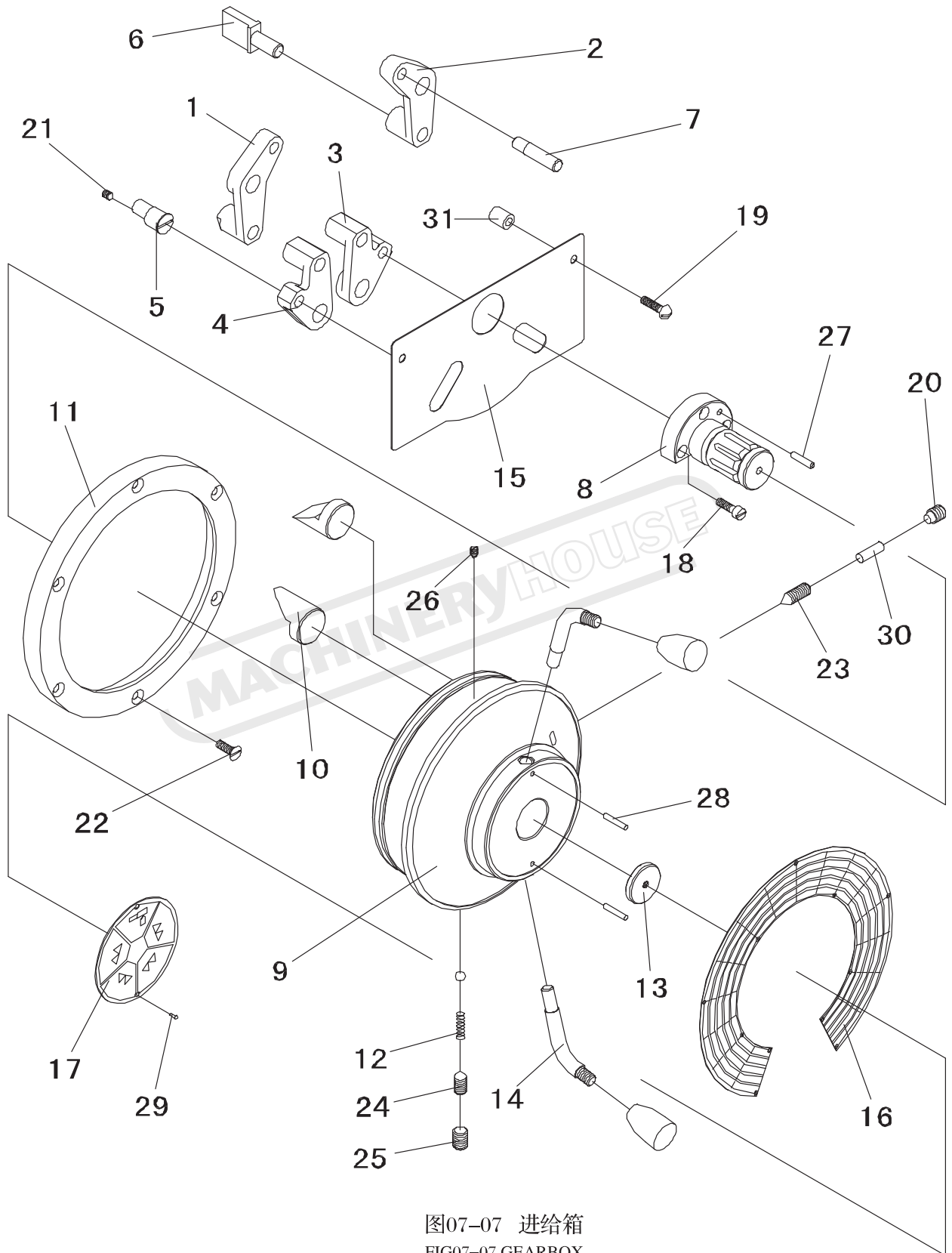
# 进给箱

## GEARBOX

图上序号 POSITION No.	件号 PART No.	名称 DESCRIPTION	数量 Q'TY	附注 REMARKS
1	CW6163C-07-069	杠 杆 SHIFTING BAR	1	
2	CW6163C-07-070	杠 杆 SHIFTING BAR	1	
3	CW6163C-07-071	杠 杆 SHIFTING BAR	1	
4	CW6163C-07-072	杠 杆 SHIFTING BAR	1	
5	CW6163C-07-073	偏 心 轴 ECCENTRIC SHAFT	4	
6	CW6163C-07-074	拨 块 SHIFTING PAD	5	
7	CW6163C-07-075	顶 销 PIN	4	
8	CW6163C-07-076	定 位 轴 HOUSING	1	
9	CW6163C-07-077	手 轮 HAND WHEEL	1	
10	CW6163C-07-078	楔 形 块 WEDGE BLOCK	2	
11	CW6163C-07-079	端 盖 RING	1	
12	GB2089	弹 簧 SPRING 1.2X7X22	1	
13	CW6163C-07-101	堵 头 PLUG	1	
14	CW6163C-07-104	手 柄 杆 SHANK ROD	2	
15	CW6163C-07-110	挡 板 PLATE	1	
16	CW6163C-07-097	进给标牌 FEED PLATE	1	
17	CW6163C-07-096A	标 牌 PLATE	1	
18	GB65	螺 钉 SCREW M6X20	3	
19	GB67	螺 钉 SCREW M6X25	2	
20	GB72	螺 钉 SCREW M12X16	1	
21	GB71	螺 钉 SCREW M6X10	4	
22	GB68	螺 钉 SCREW M6X25	6	
23	CW6163C-07-099	定位螺钉 SETTING SCREW	1	
24	GB71	螺 钉 SCREW M10X20	1	
25	GB73	螺 钉 SCREW M12X16	1	
26	GB72	螺 钉 SCREW M6X8	1	
27	GB117	圆 锥 销 TAPER PIN A-5X24	1	
28	GB117	圆 锥 销 TAPER PIN A-4X20	2	
29	GB867	铆 钉 RIVETS 2X6	16	
30	GB119	圆 柱 销 CYLINDRICAL PIN B-8X24	1	
31	CW6163C-07-112	垫 套 SPACER	2	

Purchase Parts

CW6163C



图07-08 进给箱  
FIG07-08 GEARBOX

CW6163C

Purchase Parts

部别 07  
GROUP  
插图号 07-08  
FIG No.

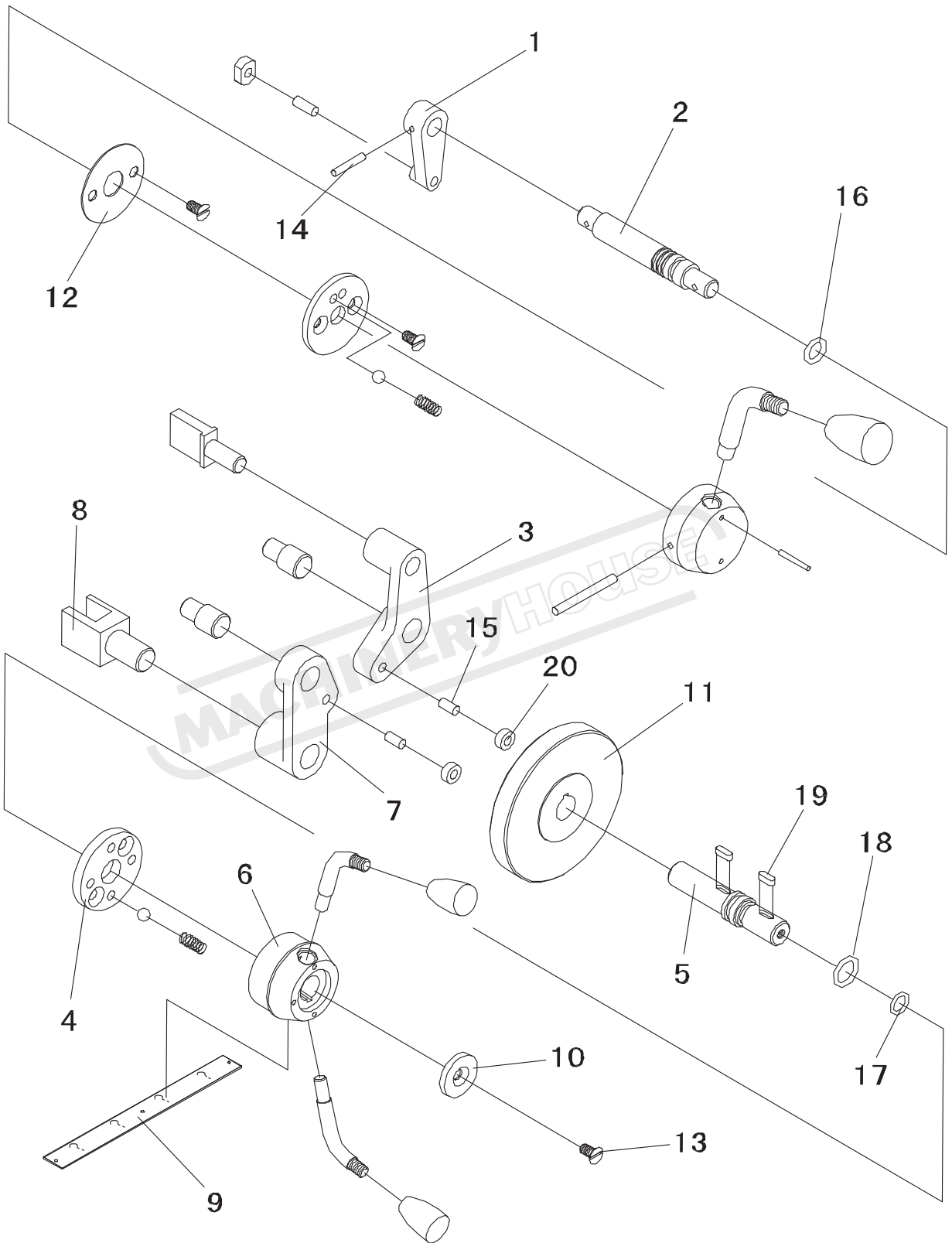
# 进给箱

## GEARBOX

图上序号 POSITION No.	件号 PART No.	名称 DESCRIPTION	数量 Q'TY	附注 REMARKS
1	CW6163C-07-080	杠 杆 SHIFTING BAR	1	
2	CW6163C-07-081	手柄轴 HANDLE ROD	1	
3	CW6163C-07-082	杠 杆 SHIFTING BAR	1	
4	CW6163C-07-083	定位垫 LOCATION PAD	1	
5	CW6163C-07-084	手柄轴 HANDLE ROD	1	
6	CW6163C-07-085	手柄座 HOUSING	1	
7	CW6163C-07-086	杠 杆 SHIFTING BAR	1	
8	CW6163C-07-087	拨 块 FORK SHIFTER	1	
9	CW6163C-07-095	标 牌 PLATE	1	
10	CW6163C-07-098	垫 GASKET	1	
11	CW6163C-07-100	盘 PLATE	1	
12	CW6163C-07-107	垫 GASKET	1	
13	GB68	螺 钉 SCREW M6X16	1	
14	GB117	圆锥销 ROUND TAPER PIN A-4X24	1	
15	GB119	圆锥销 ROUND TAPER PIN A-6X16	2	
16	GB3452.1	密封圈 SEAL RING 11.2X2.65	1	
17	GB3452.1	密封圈 SEAL RING 11.2X2.65	1	
18	GB3452.1	密封圈 SEAL RING 15X2.65	1	
19	GB1096	平 键 FLAT KEY 4X4X12	2	
20	Q99-1	滑 块 SPACER B-12	2	



CW6163C

Purchase Parts

部别 08  
GROUP  
插图号 08-01  
FIG No.

# 挂 轮

## CHANGE GEAR

图上序号 POSITION No.	件号 PART No.	名称 DESCRIPTION	数量 Q'TY	附注 REMARKS
1	CW6163C-08-011	挂 轮 板 CHANGE GEAR PLATE	1	
2	CW6163C-08-012	垫 GASKET	1	
3	CW6163C-08-013	齿 轮 GEAR	2	
4	CW6163C-08-014A	标 牌 PLATE	1	
5	CW6163C-08-015	花 键 套 SPLINE SLEEVE	1	
6	CW6163C-08-016	垫 圈 WASHER	2	
7	CW6163C-08-017A	齿 轮 GEAR	1	
8	CW6163C-08-018A	齿 轮 GEAR	1	
9	CW6163C-08-019	套 SLEEVE	1	
10	CW6163C-08-020	轴 SHAFT	1	
11	CW6163C-08-021	花 键 套 SPLINE SLEEVE	1	
12	CW6163C-08-022	垫 圈 WASHER	1	
13	CW6163C-08-023	齿 轮 GEAR	1	
14	GB5783	螺 钉 SCREW M10X20	2	
15	GB898	双头螺柱 STUD A-M24X80	1	
16	GB6170	螺 母 NUT M24	2	
17	GB97.2	垫 圈 WASHER 24	1	
18	GB1154	油 杯 OIL SEAL B-12	1	
19	CW6163C-08-027	内 隔 套 CONE SPACER	1	

Purchase Parts

CW6163C



图09-01 附件  
FIG09-01 ACCESSORIES



CW6163C

Purchase Parts

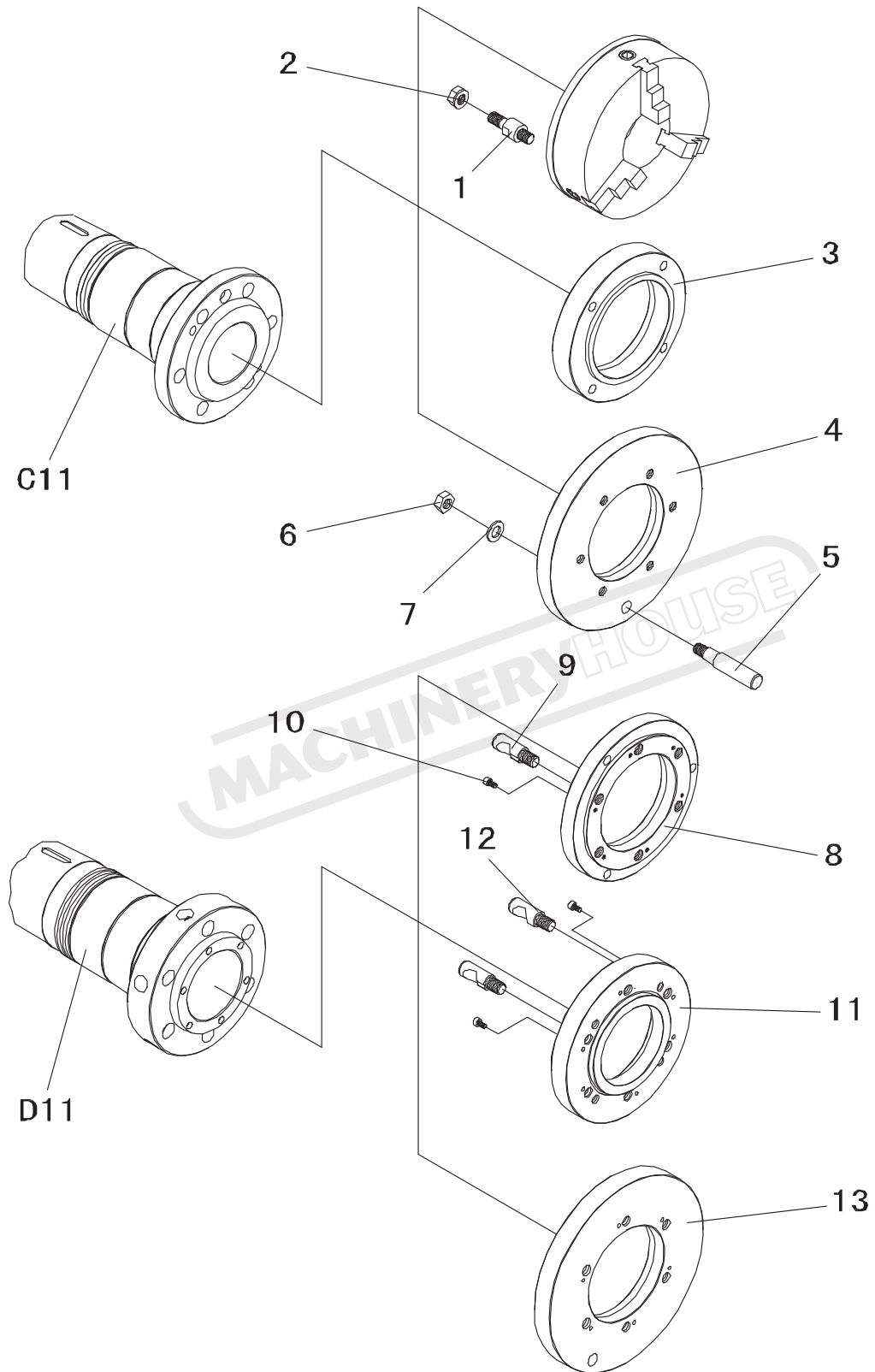
部别 09  
GROUP  
插图号 09-01  
FIG No.

## 附件 ACCESSORIES

图上序号 POSITION No.	件号 PART No.	名称 DESCRIPTION	数量 Q'TY	附注 REMARKS
1	11 DB1452	插销螺栓 DOUBLE END BOLT	6	C11主轴 SPINDLE
2	11 DB1453	带肩螺母 NUT	6	C11主轴 SPINDLE
3	CW6163C-09-011A	φ320三爪卡盘座 3-JAW CHUCK BACK PLATE	1	C11主轴 SPINDLE
4	CW6163C-09C-014	拨盘体 DRIVE PLATE	1	C11主轴 SPINDLE
4	CW6263C-09A-012	花盘体 FACE PLATE	1	C11主轴 SPINDLE
5	CW6163C-09C-015	轴 HANDLE	1	C11主轴 SPINDLE
6	GB6170	螺 母 NUT M20	1	C11主轴 SPINDLE
7	GB97.1	垫 圈 WASHER 20	1	C11主轴 SPINDLE
8	CW6163C-09D-011	φ320三爪卡盘座 3-JAW CHUCK BACK PLATE		D11主轴 SPINDLE
9	CW6163C-09D-012	拉 杆 STUD	6	D11主轴 SPINDLE
10	GB70	螺 钉 SCREW M8X16	6	D11主轴 SPINDLE
11	CW6163C-09E-013	φ500四爪卡盘座 4-JAW CHUCK BACK PLATE	1	D11主轴 SPINDLE
11	CW6263C-09b-013	φ630四爪卡盘座 4-JAW CHUCK BACK PLATE	1	D11主轴 SPINDLE
12	CW6163C-09E-015	拉 杆 STUD	2	D11主轴 SPINDLE
13	CW6263C-09D-012	花盘体 FACE PLATE	1	D11主轴 SPINDLE
13	CW6163C-09F-014	拨盘体 DRIVE PLATE	1	D11主轴 SPINDLE

Purchase Parts

CW6163C



图10B-01 中心架  
FIG10B-01 STEADY REST

CW6163C

Purchase Parts

部别 10  
GROUP  
插图号 10B-01  
FIG No.

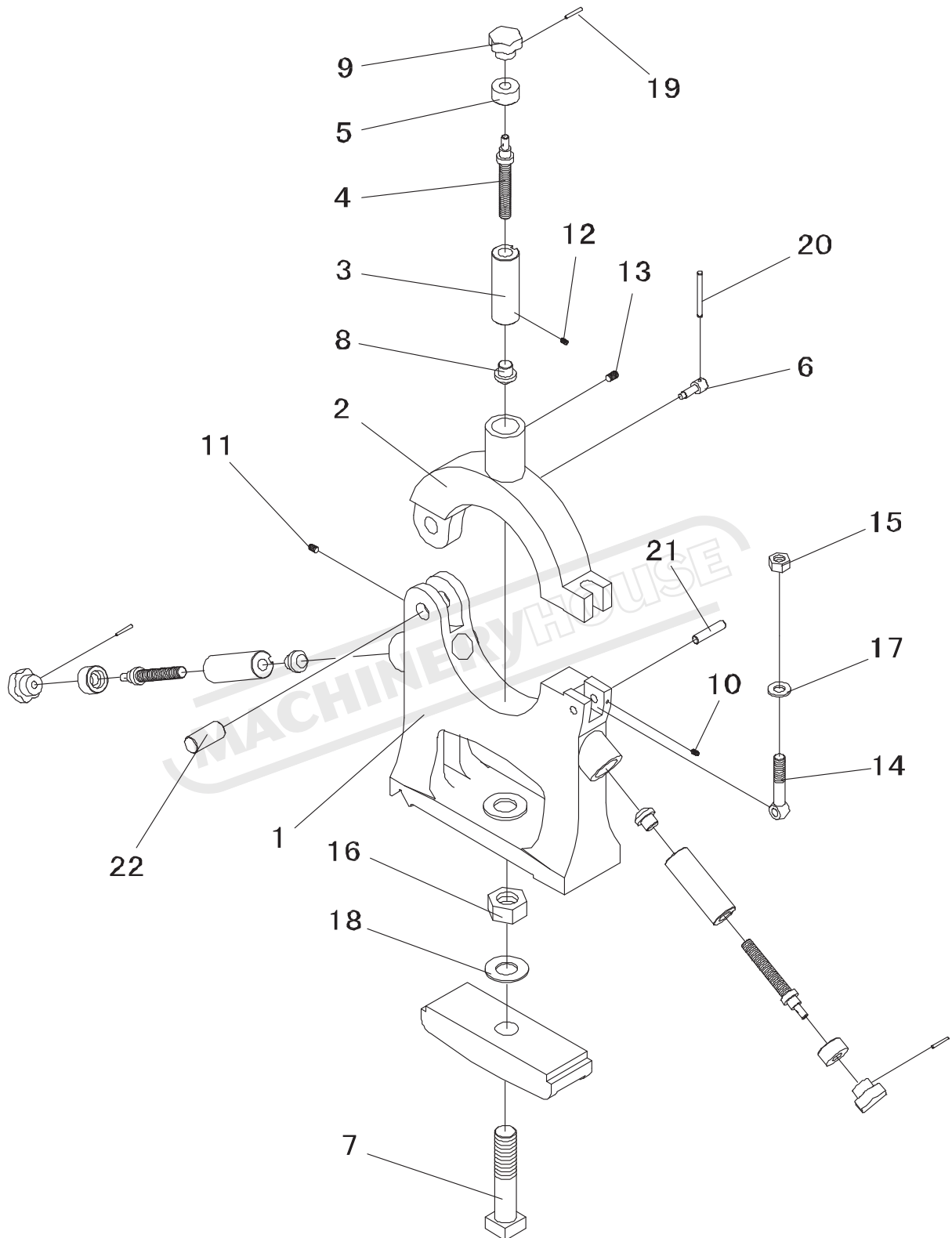
# 中心架

## STEADY REST

图上序号 POSITION No.	件号 PART No.	名称 DESCRIPTION	数量 Q'TY	附注 REMARKS
1	CW6163C-10B-011	中心架下体 STEADY REST BOTTOOM BODY	1	
2	CW6163C-10B-012	中心架上体 STEADY REST TOP BODY	1	
3	CW6163C-10B-013	滑动轴 SLIDE SHAFT	3	
4	CW6163C-10B-014	丝杠 LEAD SCREW	3	
5	CW6163C-10B-015	挡套 SPACER	3	
6	CW6163C-10B-016	螺钉 SCREW	3	
7	CW6163C-10B-017	螺钉 SCREW	1	
8	CW6163C-10B-018	顶头 STUD	3	
9	CW6163C-10B-028	手柄 HAND WHEEL	3	
10	GB71	螺钉 SCREW M6X12	1	
11	GB71	螺钉 SCREW M8X20	1	
12	GB71	螺钉 SCREW M6X8	3	
13	GB72	螺钉 SCREW M10X12	3	
14	GB798	活节螺栓 EYELET BOLT M16X90	1	
15	GB6170	螺母 NUT M16	1	
16	GB56	螺母 NUT M30	1	
17	GB97.1	垫圈 WASHER 16	1	
18	GB97.1	垫圈 WASHER 30	1	
19	GB117	圆锥销 TAPER PIN B-4X30	3	
20	GB119	圆柱销 CYLINDRICAL PIN A-6X70	3	
21	GB119	圆柱销 CYLINDRICAL PIN A-12X55	1	
22	GB119	圆柱销 CYLINDRICAL PIN A-25X55	1	

Purchase Parts

CW6163C



图10C-01 跟刀架  
FIG10C-01 FOLLOW REST

CW6163C

Purchase Parts

部别 10  
GROUP  
插图号 10C-01  
FIG No.

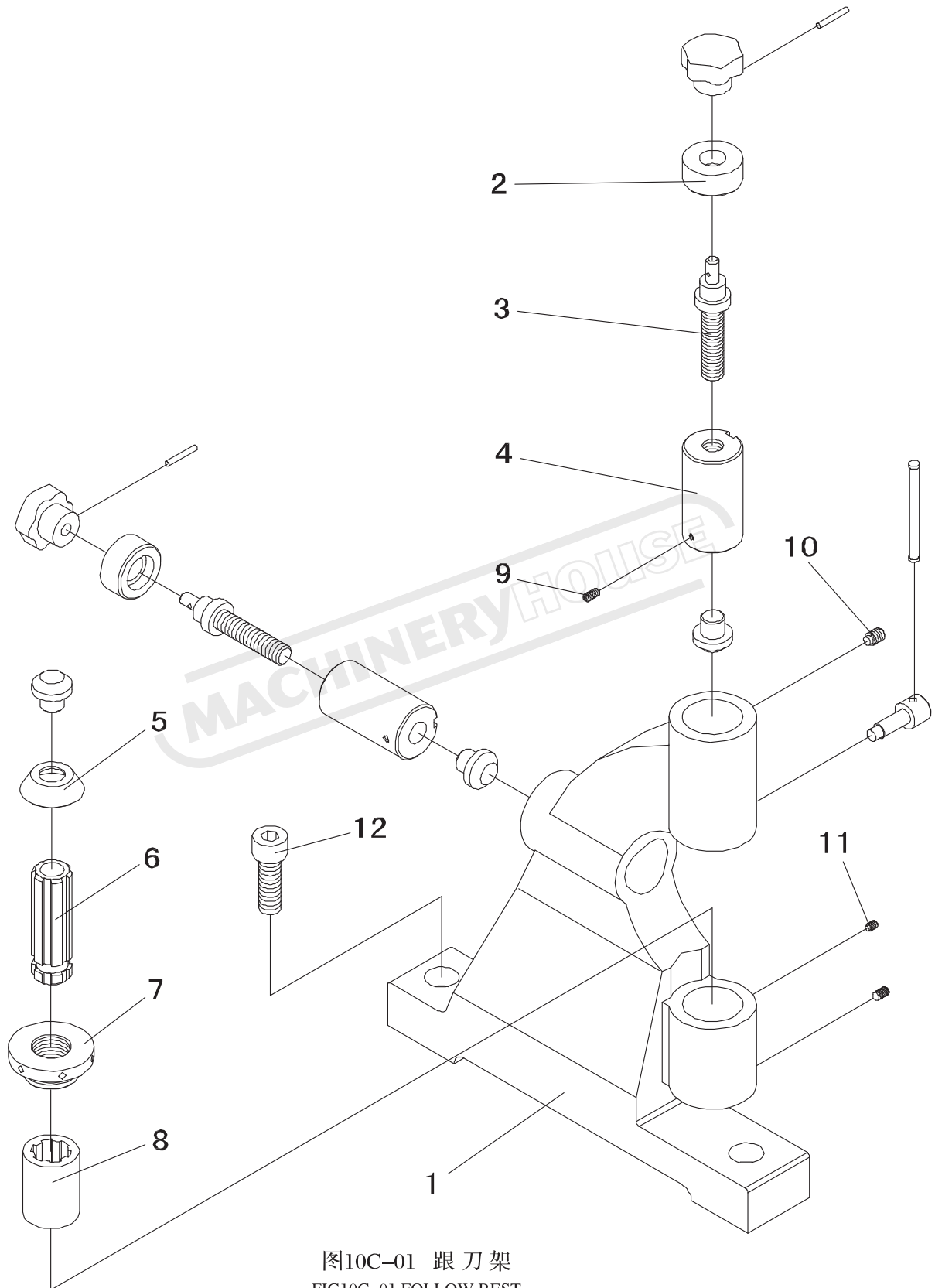
跟刀架  
FOLLOW REST

图上序号 POSITION No.	件号 PART No.	名称 DESCRIPTION	数量 Q'TY	附注 REMARKS
1	CW6163C-10C-019	跟刀架体 FOLLOW REST BODY	1	
2	CW6163C-10C-020	挡 套 SPACER	2	
3	CW6163C-10C-021	丝 杠 LEAD SCREW	2	
4	CW6163C-10C-022	滑 动 轴 SLIDE SHAFT	2	
5	CW6163C-10C-023	顶 头 CONE SPACER	3	
6	CW6163C-10C-025	花 键 轴 SPLINE SHAFT	1	
7	CW6163C-10C-026	螺 母 NUT	1	
8	CW6163C-10C-027	花 键 套 SPLINE SLEEVE	1	
9	GB71	螺 钉 SCREW M6X12	3	
10	GB72	螺 钉 SCREW M10X12	2	
11	GB72	螺 钉 SCREW M6X12	1	
12	GB70	螺 钉 SCREW M16X50	2	

Purchase Parts

CW6163C



图11-01 床身及固定装置  
 FIG11 01 BED AND FIXING DEVICE

CW6163C

Purchase Parts

部别

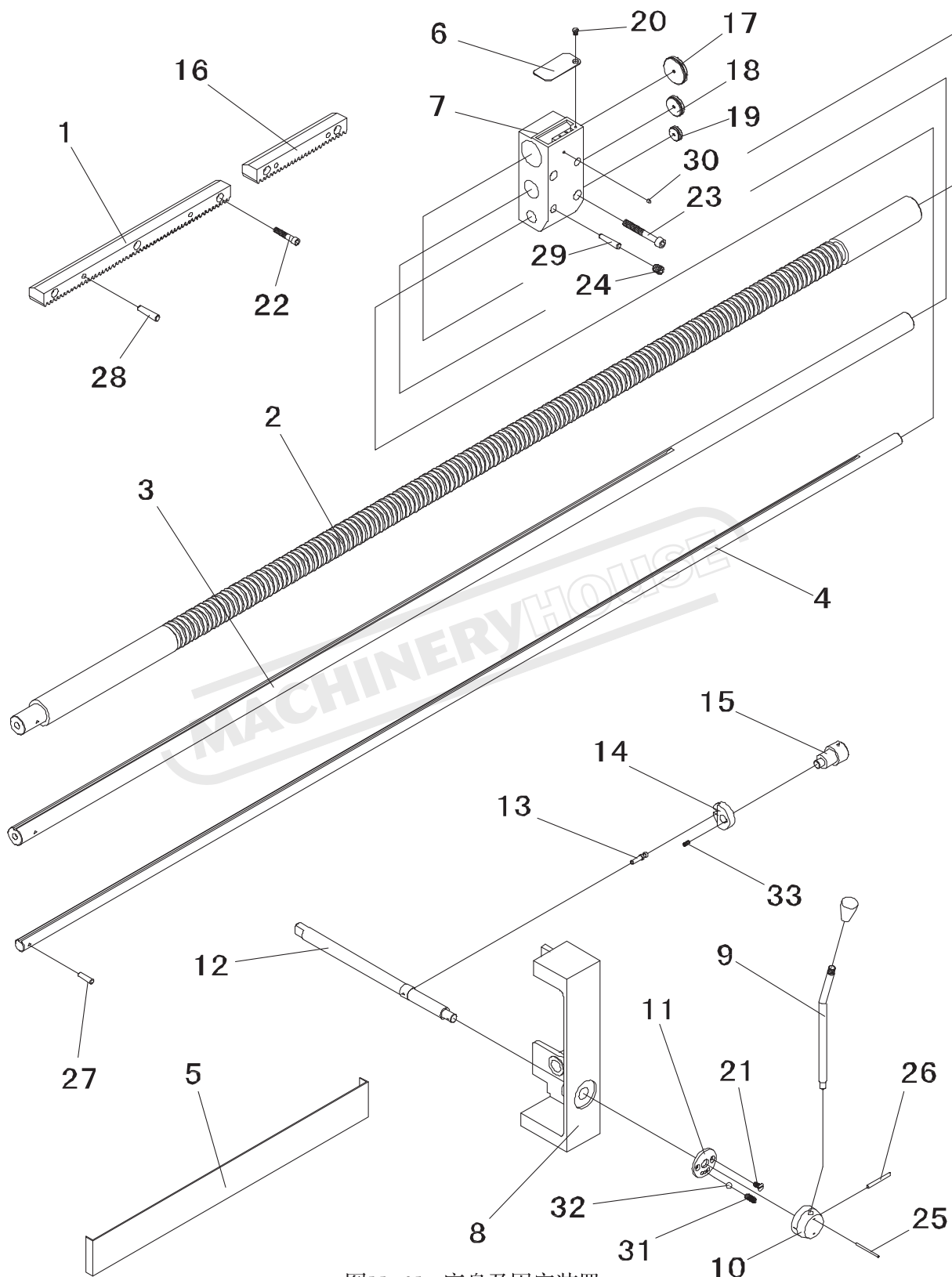
11

GROUP

插图号

11-01

FIG No.

## 床身及固定装置

## BED AND FIXING DEVICE

图上序号 POSITION No.	件号 PART No.	名称 DESCRIPTION	数量 Q'TY	附注 REMARKS
1	CW6163C-11-011	齿条 RACK	3/4-5/7	
2	CW6163C-11-012/1000	丝杠 LEAD SCREW	1	1000
2	CW6163C-11-012/1500	丝杠 LEAD SCREW	1	1500
2	CW6163C-11-012/2000	丝杠 LEAD SCREW	1	2000
2	CW6163C-11-012/3000	丝杠 LEAD SCREW	1	3000
3	CW6163C-11-013/1000	光杠 FEED SHAFT	1	1000
3	CW6163C-11-013/1500	光杠 FEED SHAFT	1	1500
3	CW6163C-11-013/2000	光杠 FEED SHAFT	1	2000
3	CW6163C-11-013/3000	光杠 FEED SHAFT	1	3000
4	CW6163C-11-014/1000	变向杠 REVERSED BAR	1	1000
4	CW6163C-11-014/1500	变向杠 REVERSED BAR	1	1500
4	CW6163C-11-014/2000	变向杠 REVERSED BAR	1	2000
4	CW6163C-11-014/3000	变向杠 REVERSED BAR	1	3000
5	CW6163C-11-015	挡板 BAFFLE	1	
6	CW6163C-11-016	托架盖 BRACKET COVER	1	
7	CW6163C-11-017	托架 BRACKET	1	
8	CW6163C-11-018	操纵架 STEERING FRAME	1	
9	CW6163C-11-028	手柄杆 SHANK ROD	1	
10	CW6163C-11-029	手柄座 SHANK SEAT	1	
11	CW6163C-11-030	垫 PAD	1	
12	CW6163C-11-031	杆 ROD	1	
13	CW6163C-11-032	销子 PIN	1	
14	CW6163C-11-033	拨块 DRIVING BLOCK	1	
15	CW6163C-11-034	小轴 SMALL SHAFT	1	
16	CW6163C-11-035	齿条 RACK	1/1-2/2	
17	CW6163C-11-036	堵 PLUG	1	
18	CW6163C-11-037	堵 PLUG	1	
19	CW6163C-11-038	堵 PLUG	1	

## Purchase Parts

CW6163C

部别  
GROUP  
插图号  
FIG No.

11  
11-01

床身及固定装置  
BED AND FIXING DEVICE

图上序号 POSITION No.	件号 PART No.	名称 DESCRIPTION	数量 Q'TY	附注 REMARKS
20	GB68	螺 钉 SCREW M6X8	1	
21	GB68	螺 钉 SCREW M6X12	2	
22	GB70	螺 钉 SCREW M10X45	11/14-17/23	
23	GB70	螺 钉 SCREW M12X90	2	
24	GB78	螺 钉 SCREW M16X16	2	
25	GB117	圆锥销 ROUND TAPER PIN A-3X25	1	
26	GB117	圆锥销 ROUND TAPER PIN A-6X60	1	
27	GB118	圆锥销 ROUND TAPER PIN A-8X35	1	
28	GB118	圆锥销 ROUND TAPER PIN A-10X60	8/10-12/16	
29	GB118	圆锥销 ROUND TAPER PIN A-10X50	2	
30	Q56-1	堵 塞 PLUG 6	2	
31	GB2089	弹 簧 SPRING 1X7X25	1	
32	GB308	钢 球 STEEL BALL $\phi$ 8G200b	1	
33	GB71	螺 钉 SCREW M6X12	1	



**CW6163C**

**Purchase Parts**



图14-01 冷却系统  
FIG14-01 COOLANT SYSTEM

Purchase Parts

CW6163C

部别 14

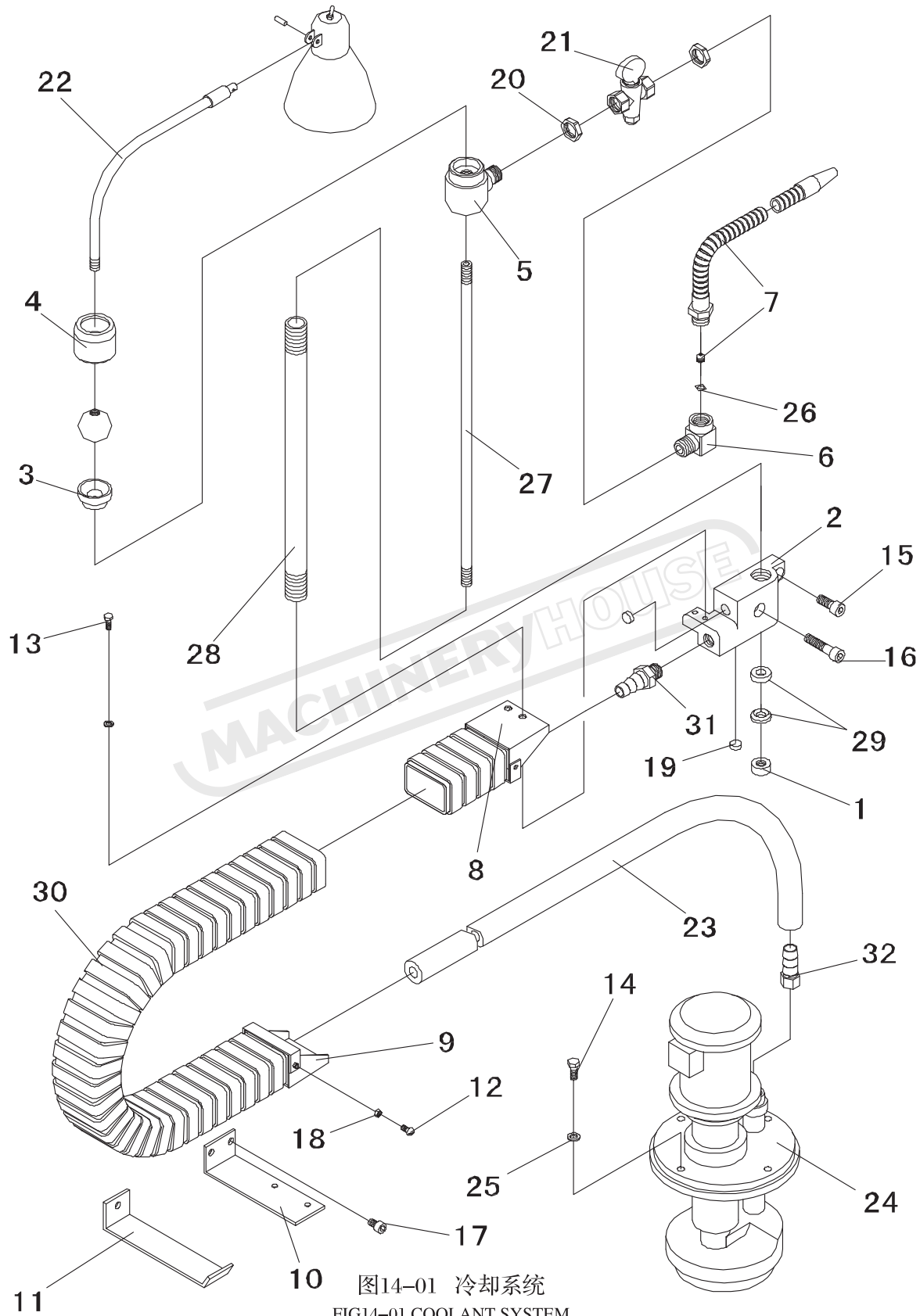
GROUP  
插图号  
FIG No.

14-01

# 冷却系统

## COOLANT SYSTEM

图上序号 POSITION No.	件号 PART No.	名称 DESCRIPTION	数量 Q'TY	附注 REMARKS
1	CW6163C-14-011	接头 JOINT	1	
2	CW6163C-14-012A	座体 HOUSING	1	
3	CW6163C-14-014	橡皮垫 RUBBER WASHER	1	
4	CW6163C-14-015	压盖 NUT	1	
5	CW6163C-14-020	三通接头 T-JOINT	1	
6	CW6163C-14-023	直角管接头 STRAIGHT ANGLE JOINT	1	
7	CW6163C-14-025	能动金属软管焊接组件 PIPE	1	套 SET
10	CW6163C-14-026A	支架 BRACKET	2	
12	GB67	螺钉 SCREW M6X12	2	
13	GB5783	螺钉 SCREW M6X10-Zn.D	2	
14	GB5783	螺钉 SCREW M8X20	4	
15	GB70	螺钉 SCREW M10X25	1	
16	GB70	螺钉 SCREW M10X45	1	
17	GB5783	螺钉 SCREW M8X12	3/4-5/6	
18	GB6170	螺母 NUT M6	4	
19	Q56-1	堵塞 PLUG 6n6	2	
20	JB/GQ0315	管螺母 TUBULAR NUT G1/2	2	
21	L81-1	活栓 VALVE G1/2	1	套 SET
22		照明灯 WORK LAMP	1	套 SET
23	HG4-761	胶管 HOSE $\phi$ 8X1500-100	1	1000
		胶管 HOSE $\phi$ 8X1760-100	1	1500
		胶管 HOSE $\phi$ 8X2020-100	1	2000
		胶管 HOSE $\phi$ 8X2475-100	1	3000
24	AOB-25	冷却泵 COOLING PUMP	1	套 SET
25	GB97.1	垫圈 WASHER 8	4	

CW6163C

Purchase Parts

部别 14  
GROUP  
插图号 14-01  
FIG No.

# 冷却系统

## COOLANT SYSTEM

图上序号 POSITION No.	件号 PART No.	名称 DESCRIPTION	数量 Q'TY	附注 REMARKS
26	JB/GQ0332	垫 圈 WASHER 12	1	
27	CW6163C-14-033	螺纹管 SCREWED TUBE G1/4X373	1	
28	CW6163C-14-032	螺纹管 SCREWED TUBE G3/4X300	1	
29	JB/GQ0326	密封圈 SEAL RING 12X24	1	
		密封圈 SEAL RING C-12X24	1	
30	CW6163C-14-030A/1000	拖 链 LAG DRAG CHAIN	1	套 SET
	CW6163C-14-030A/1500	拖 链 LAG DRAG CHAIN	1	套 SET
	CW6163C-14-030A/2000	拖 链 LAG DRAG CHAIN	1	套 SET
	CW6163C-14-030A/3000	拖 链 LAG DRAG CHAIN	1	套 SET
31	JB/GQ0341	直通管接头 STRAIGHT PIPE JOINT	1	
32	G31-7A	管 箍 PIPE HOOP 20	2	套 SET

Purchase Parts

CW6163C



图15-01 电机装置  
FIG15-01 MOTOR DEVICE

CW6163C

Purchase Parts

部别 15  
GROUP  
插图号 15-01  
FIG No.

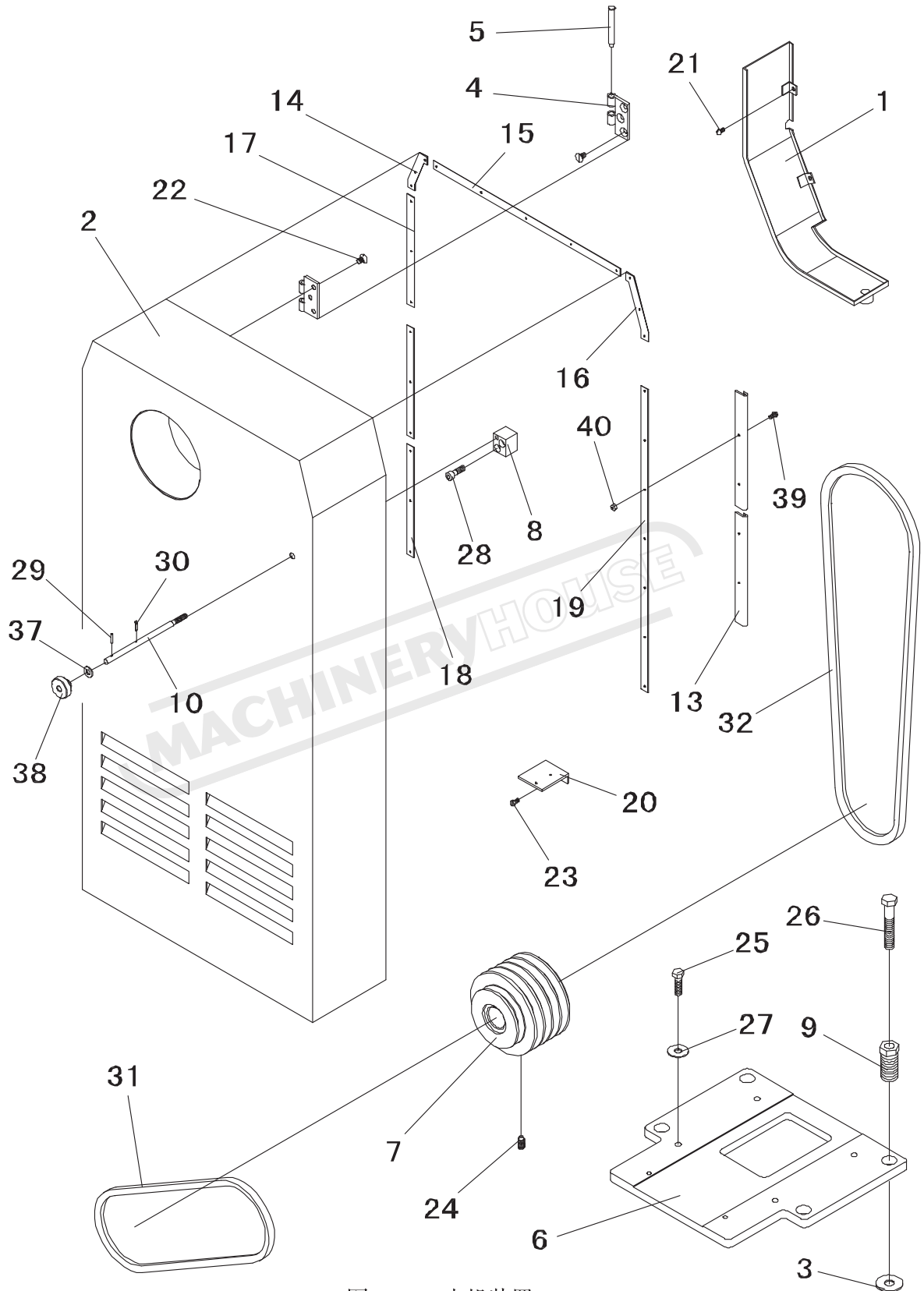
# 电机装置

## MOTOR DEVICE

图上序号 POSITION No.	件号 PART No.	名称 DESCRIPTION	数量 Q'TY	附注 REMARKS
		接油盘焊接件 OIL TRAY RECEIVING	1	
2	CW6163C-15-012	挂轮罩焊接件 CHANGE GEAR COVER	1	
3	CW6163C-15-014	垫 WASHER	4	
4	CW6163C-15-017	铰 链 HINGE	4	
5	CW6163C-15-018	铰 链 轴 HINGE STUD	2	
6	CW6163C-15-019	电机底座 MOTOR MOUNTING PLATE	1	
7	CW6163C-15-023B	皮 带 轮 PULLEY	1	
8	CW6163C-15-033	座 SEAT	1	
9	CW6163C-15-036	调 整 套 ADJUSTING SREW	4	
10	CW6163C-15-040	螺 钉 轴 SCREW PIN	1	
13	CW6163C-15-043	胶 条 RUBBER STRIP	1	
14	CW6163C-15-044	压 边 板 CLAMPING PLATE	1	
15	CW6163C-15-045	压 边 板 CLAMPING PLATE	1	
16	CW6163C-15-046	压 边 板 CLAMPING PLATE	1	
17	CW6163C-15-047	压 边 板 CLAMPING PLATE	1	
18	CW6163C-15-048	压 边 板 CLAMPING PLATE	1	
19	CW6163C-15-049	压 边 板 CLAMPING PLATE	1	
20	CW6163C-15-050	支 架 SUPPORT	1	
21	GB67	螺 钉 SCREW M6X12	2	
22	GB68	螺 钉 SCREW M8X16	2	
23	GB65	螺 钉 SCREW M6X12	2	
24	GB72	螺 钉 SCREW M12X25	1	
25	GB5783	螺 钉 SCREW M12X35	4	
26	GB5782	螺 钉 SCREW M16X100	4	
27	GB97.1	垫 圈 WASHER 12	4	
28	GB70	螺 钉 SCREW M8X30	2	

## Purchase Parts

CW6163C

部别 15  
GROUP  
插图号 15-01  
FIG No.

电机装置  
MOTOR DEVICE

图上序号 POSITION No.	件号 PART No.	名称 DESCRIPTION	数量 Q'TY	附注 REMARKS
29	GB117	圆锥销 ROUND TAPER PIN A-3X20	1	
30	GB91	开口销 SPLIT PIN 3.2X16	1	
31	GB1171	普通V带GENERAL V BELT A947	1	
32	GB1171	普通V带GENERAL V BELT B1920	1	
37	GB97.1	垫圈 WASHER 10	1	
38		把手 FLATHEAD HANDLE	1	
39	GB67	螺钉 SCREW M3X12	32	
40	GB6170	螺母 NUT M3	32	

CW6163C

Purchase Parts



图20-01 电气箱  
FIG20-01 ELECTRIC BOX

## Purchase Parts

CW6163C

部别 20  
GROUP  
插图号 20-01  
FIG No.

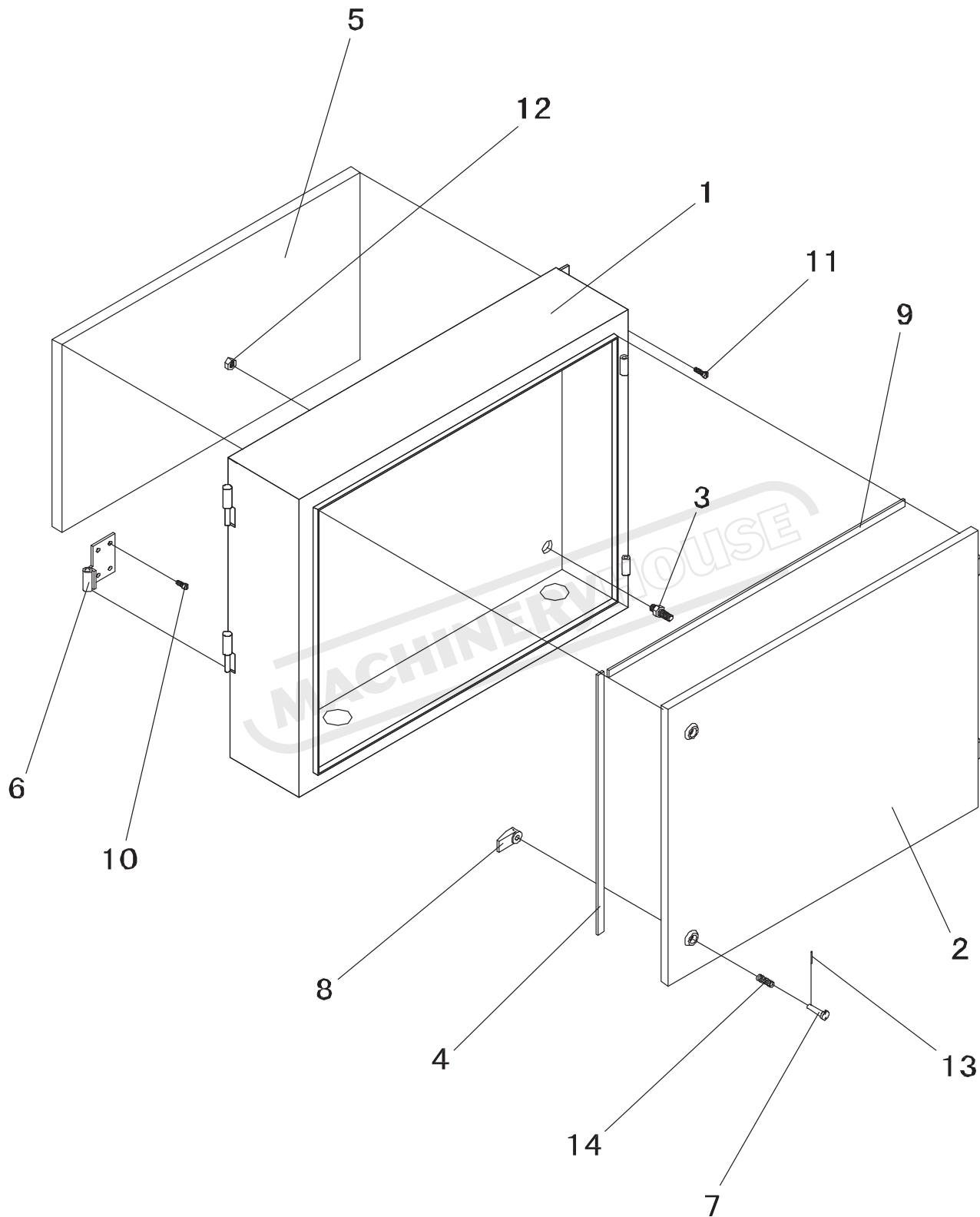
电气箱  
ELECTRIC BOX

图上序号 POSITION No.	件号 PART No.	名称 DESCRIPTION	数量 Q'TY	附注 REMARKS
1	CW6163C-20-011	电箱焊接件 ELECTRIC CABINET	1	
2	CW6163C-20-012	电箱盖焊接件 DOOR	1	
3	CW6163C-20-013	双头螺栓 STUD	4	
4	CW6163C-20-014	密封条 RUBBER SEAL	2	
5	CW6163C-20-015	泡沫塑料板 EXPANDED PLASTIC PLATE	1	
6	CW6163C-20-016	铰链焊接件 HINGE	2	
7	CW6163C-20-017	门栓轴 DOOR STUD	2	
8	CW6163C-20-018	门栓 LOCKING PAD	2	
9	CW6163C-20-019	密封条 RUBBER SEAL	2	
10	GB5783	螺钉 SCREW M6X16	8	
11	GB65	螺钉 SCREW M6X20	2	
12	GB6172	螺母 NUT M10	4	
13	GB117	圆锥销 ROUND TAPER PIN A-3X20	2	
14	GB2089	弹簧 SPRING 1.2X10X19	2	



**CW6163C**

**Purchase Parts**



图72-01 管路  
FIG72-01 PIPE LINE

## Purchase Parts

CW6163C

部别 72  
GROUP  
插图号 72-01  
FIG No.

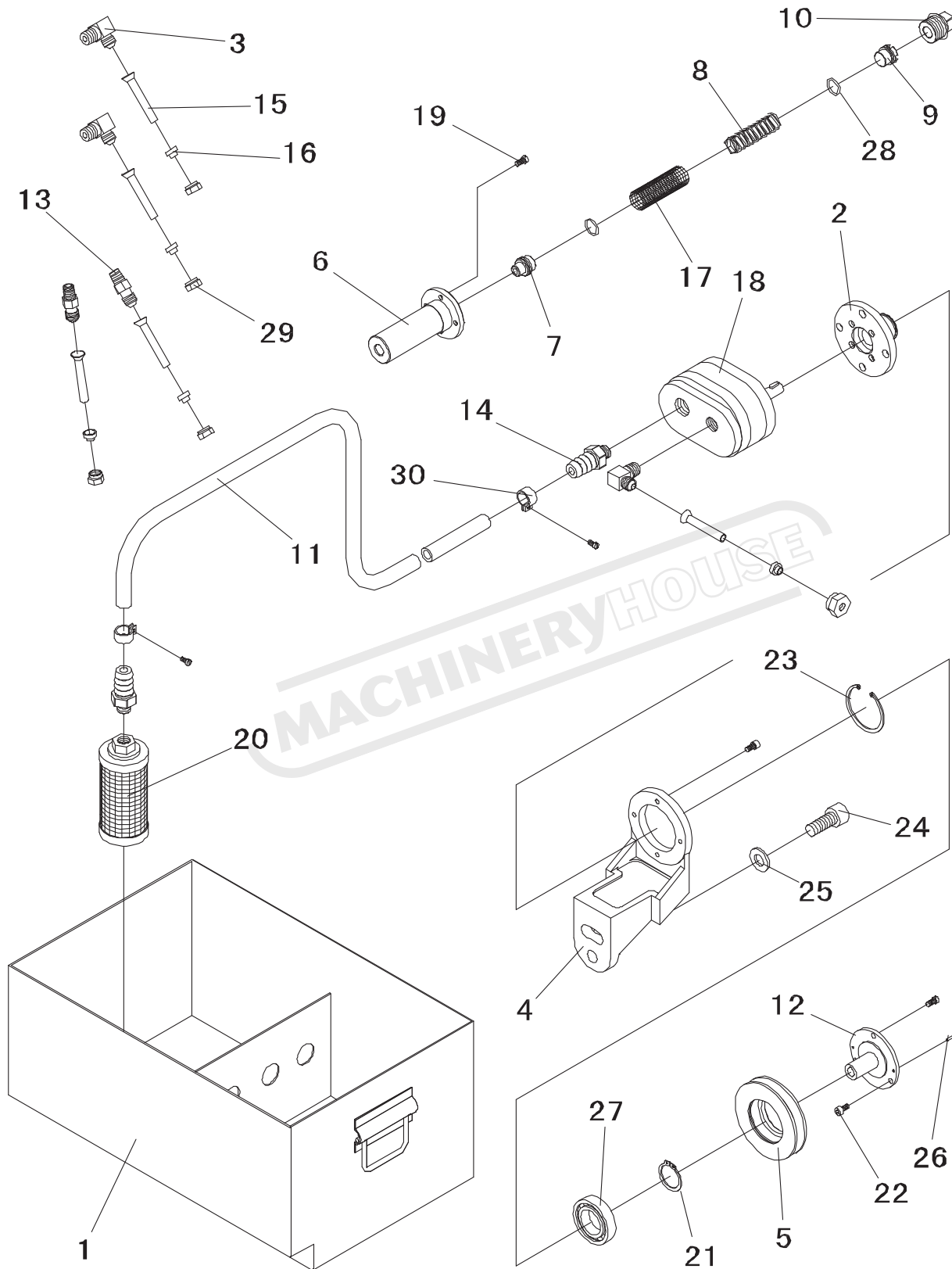
管 路  
PIPE LINE

图上序号 POSITION No.	件号 PART No.	名称 DESCRIPTION	数量 Q'TY	附注 REMARKS
1	CW6163C-72-011	油箱焊接件 OIL TANK	1	
2	CW6163C-72-012	轴承座 BEARING HOUSING	1	
3	GB5629.1	管接头 PIPE JOINT A-10-Z1/4	4	套SET
4	CW6163C-72-014	支 架 SUPPORT	1	
5	CW6163C-72-017	皮 带 轮 PULLEY	1	
6	CW6163C-72-015/1	体 PLUG	1	
7	CW6163C-72-015/2	堵 PLUG	1	
8	CW6163C-72-015/3	弹 簧 SPRING	1	
9	CW6163C-72-015/4	堵 PLUG	1	
10	CW6163C-72-015/5	丝堵接头 PIPE PLUG JOINT	1	
11	HG4-761	胶 管 HOSE $\phi 19 \times 1300-100$	1	
12	CW6163C-72-019	盖 COVER	1	
13	CW6163C-72-033	管接头 PIPE JOINT	2	
14	CW6163C-72-013	接 头 TERMINAL	1	
15	GB1527	铜 管 COPPER PIPE $\phi 10 \times 1 \times 1370 \text{M}$	1	
16	GB5646	管 套 PIPE LINER 10	3	
17		铜 网 COPPER NET 32/cm 100X90	1	
18	CB-B6	齿 轮 泵 GEARE PUMP 6X25	1	
19	GB65	螺 钉 SCREW M6X12	4	
20	FW-210	滤 油 器 OIL-FILTER	1	
21	GB894.1	弹性挡圈 SCREW 35	1	
22	GB70	螺 钉 SCREW M6X12	8	
23	GB893.1	弹性挡圈 SNAP RING 62	1	
24	GB70	螺 钉 SCREW M16X40	2	
25	GB95	垫 圈 WASHER 16	2	
26	GB117	圆 锥 销 ROUND TAPER PIN A-3X12	2	
27	GB301-64	轴 承 BEARING 80107	1	
28	D <sub>2</sub> J69-1	锁紧圈 CLAMPING RING 23	2	套SET
29	Y91-1	螺 母 NUT M16X1.5	5	
30	G31-7A	管 箍 PIPE HOOP 32	2	套SET

CW6163C

Purchase Parts



图72-02 管路  
FIG72-02 PIPE LINE

## Purchase Parts

CW6163C

部别 72  
GROUP  
插图号 72-02  
FIG No.

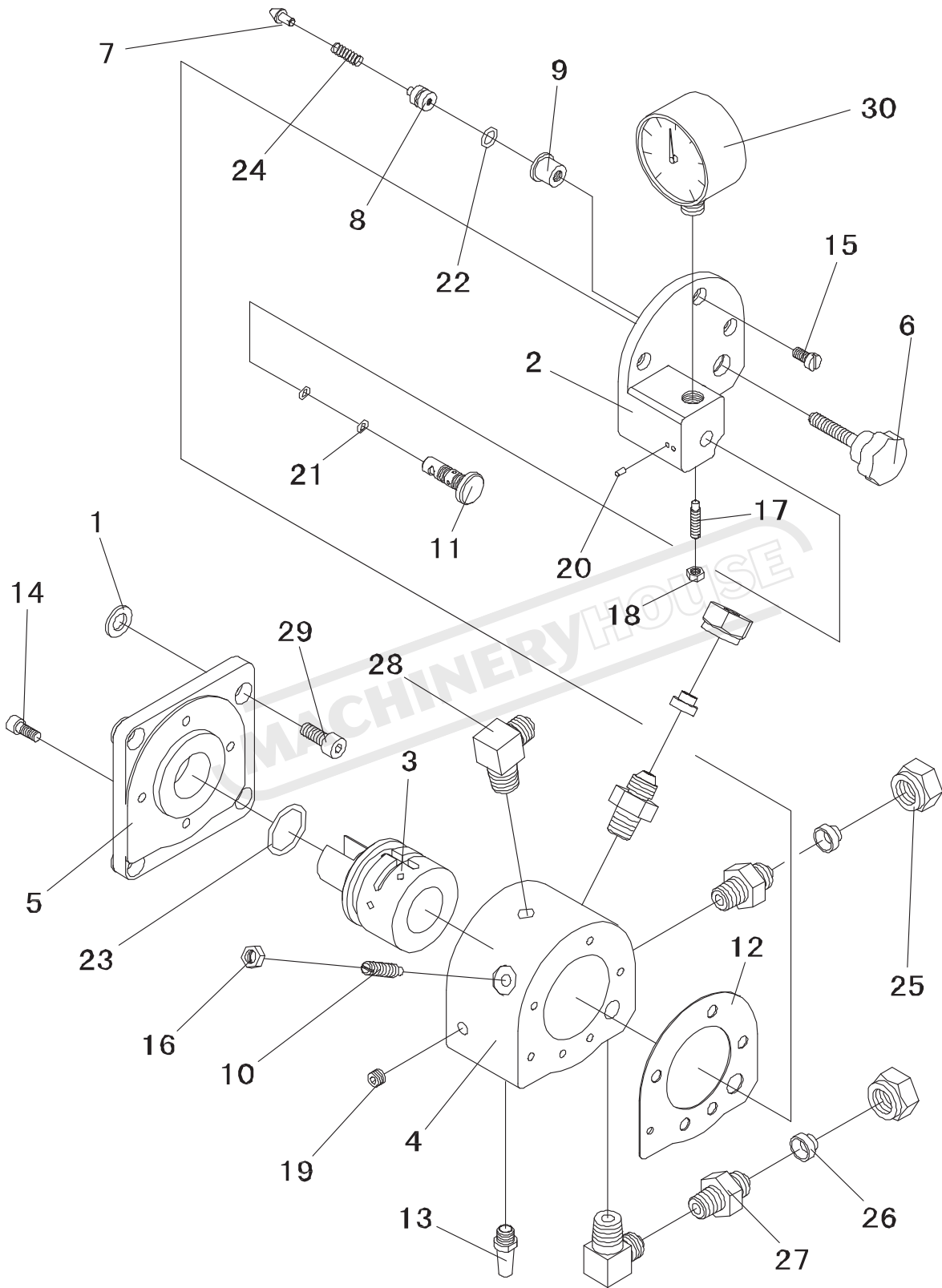
管 路  
PIPE LINE

图上序号 POSITION No.	件号 PART No.	名称 DESCRIPTION	数量 Q'TY	附注 REMARKS
1	CW6163C-72-016	垫 WASHER	1	
2	CW6163C-72-021	前 盖 HOUSING	1	
3	CW6163C-72-022	阀 VALVE	1	
4	CW6163C-72-023	阀 体 VALVE BODY	1	
5	CW6163C-72-024	底 座 BASE PLATE	1	
6	CW6163C-72-026	星行把手 STAR TYPE HANDKNOB	1	
7	CW6163C-72-027	锥 阀 TAPER-SEAT	1	
8	CW6163C-72-028	弹 簧 座 SPRING HOLDER	1	
9	CW6163C-72-029	套 SLEEVE	1	
10	CW6163C-72-030	定位螺钉 LOCKING SCREW	1	
11	CW6163C-72-031	开 关 芯 SWITCH CORE	1	
12	CW6163C-72-032	前 盖 垫 FORE COVER PAD	1	
13	CW6163C-72-035	管 接 头 PIPE JOINT	1	
14	GB70	螺 钉 SCREW M6X12	4	
15	GB65	螺 钉 SCREW M6X12	4	
16	GB6170	螺 母 NUT M8	1	
17	GB75	螺 钉 NUT M6X20	1	
18	GB6170	螺 母 NUT M6	1	
19	JB/GQ0318	油 塞 PLUG Z1/8"	1	
20	GB119	圆 柱 销 CYLINDRICAL PIN A-3X6	2	
21	GB3452.1	密 封 圈 SEAL RING 6.7X1.8	2	
22	GB3452.1	密 封 圈 SEAL RING 9X1.8	1	
23	GB3452.1	密 封 圈 SEAL RING 25X2.65	1	
24	GB2089	弹 簧 SPRING 1.2X7X22	1	
25	Y91-1	螺 母 NUT M16X1.5	5	
26	GB5646	管 套 PIPE LINER 10	5	
27	GB5626.1	管 接 头 PIPE JOINT A-10-Z1/4"	3	
28	GB5629.1	管 接 头 PIPE JOINT A-10-Z1/4"	2	
29	GB70	螺 钉 SCREW M8X20	4	
30	Y-60	压 力 表 MANOMETER 2.5MPa	1	

CW6163C

Purchase Parts



图74-01 三爪卡盘防护罩  
FIG74-01 3-JAW CHUCK GUARD

Purchase Parts

CW6163C

部别 74  
GROUP  
插图号 74-01  
FIG No.

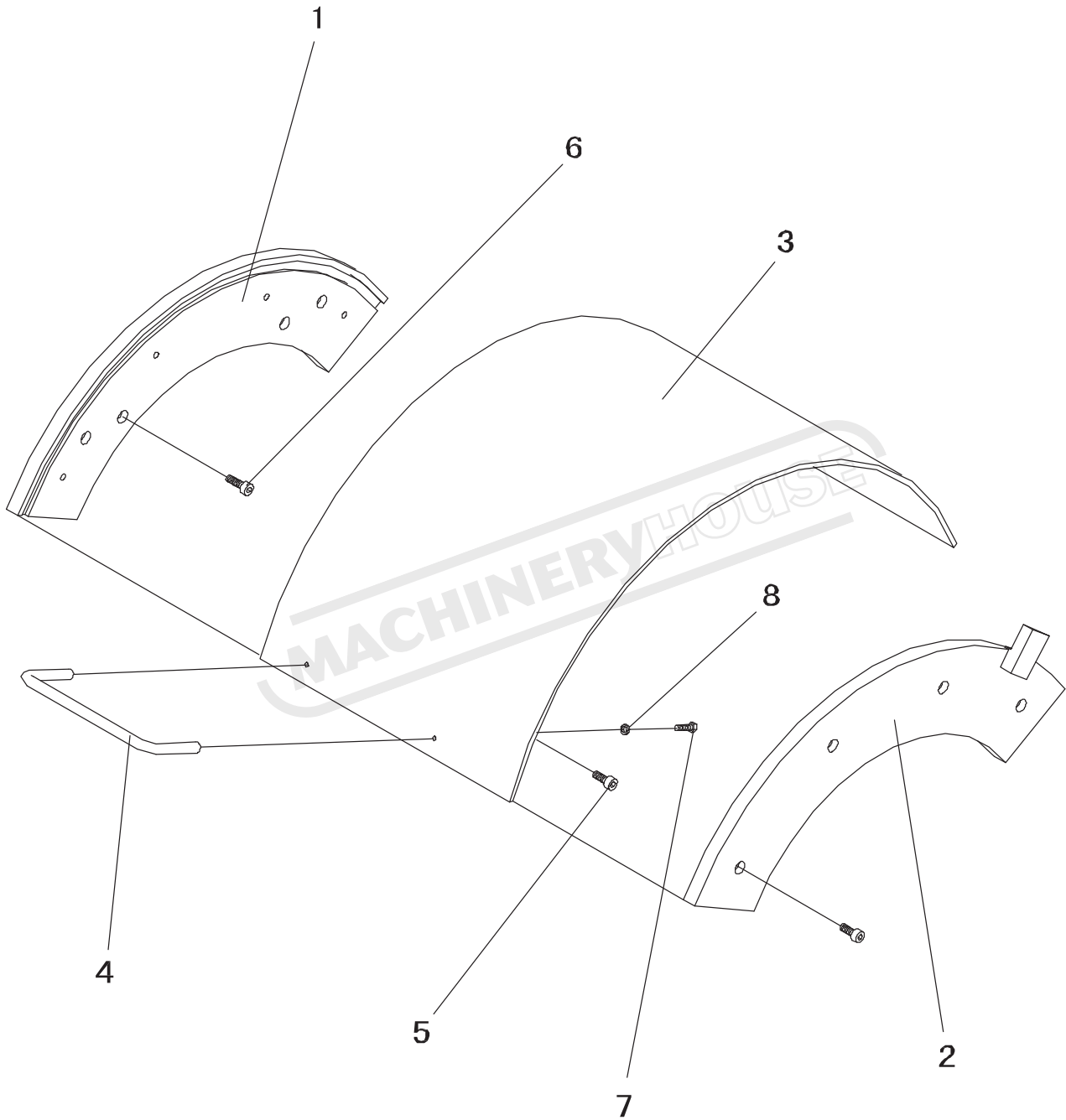
## 三爪卡盘防护罩

### 3-JAW CHUCK GUARD

图上序号 POSITION No.	件号 PART No.	名称 DESCRIPTION	数量 Q'TY	附注 REMARKS
1	CW6163C-74-011A	内 环 INTERNAL RING	1	
2	CW6163C-74-012A	外 环 OUTER RING	1	
3	CW6163C-74-013	罩 体 COVER BODY	1	
4	CW6163C-74-014	把 手 HANDLE	1	
5	GB70	螺 钉 SCREW M5X12	6	

MACHINERYHOUSE

CW6163C

Purchase Parts



图76-01 前挡屑装置

FIG76-01 FRONT CHIP PROTECTION DEVICE

Purchase Parts

CW6163C

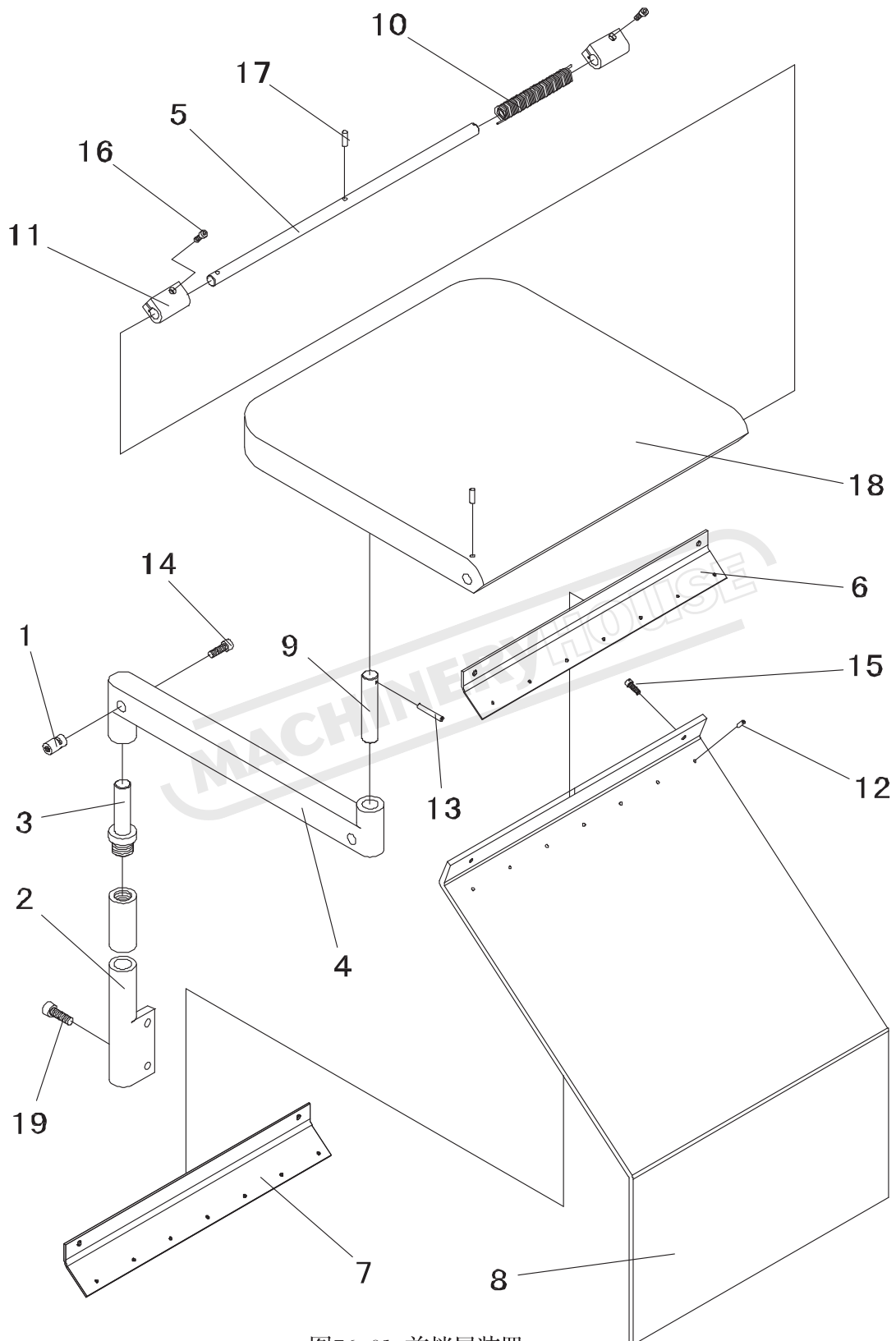
部别 76

GROUP  
插图号  
FIG No.

76-01

## 前挡屑装置

## FRONT CHIP PROTECTION DEVICE

图上序号 POSITION No.	件号 PART No.	名称 DESCRIPTION	数量 Q'TY	附注 REMARKS
1	CW6163C-76-011	夹 紧 块 GRIP SLIDE	2	
2	CW6163C-76-012	立 柱 UPRIGHT COLUMN	1	
3	CW6163C-76-013	转 轴 SPIN AXIS	1	
4	CW6163C-76-014	杠 杆 SWIFTING BAR	1	
5	CW6163C-76-015	轴 SHAFT	1	
6	CW6163C-76-016	内加固板 INTER GUSSET PLATE	1	
7	CW6163C-76-017	外加固板 OUT GUSSET PLATE	1	
8	26.1036. 1118-02	防 护 板 GUARD PLATE	1	
9	26.1036. 1117-02	销 钉 DOWELPIN	1	
10	26.1036. 1121-10	扭 簧 TORSION	1	
11	26.1036. 1139-00	夹 紧 块 GRIP SLIDE	2	
12		抽芯铆钉 CORE RIVER $\Phi 4 \times 14$	7	
13	GB879	弹性圆柱销 ELASTIC CYLINDRICAL PIN 6X40	1	
14	GB70	螺 钉 SCREW M8X25	2	
15	GB65	螺 钉 SCREW M6X16	2	
16	GB70	螺 钉 SCREW M6X16	2	
17	GB879	弹性圆柱销 ELASTIC CYLINDRICAL PIN 6X20	2	
18	26.1036. 1115-10	盖 COVER	1	
19	GB70	螺 钉 SCREW M10X25	2	



CW6163C

Purchase Parts



图95-01 纵向挡铁  
FIG95-01 LOGNITUDINAL BED STOP

Purchase Parts

CW6163C

部别  
GROUP  
插图号  
FIG No.

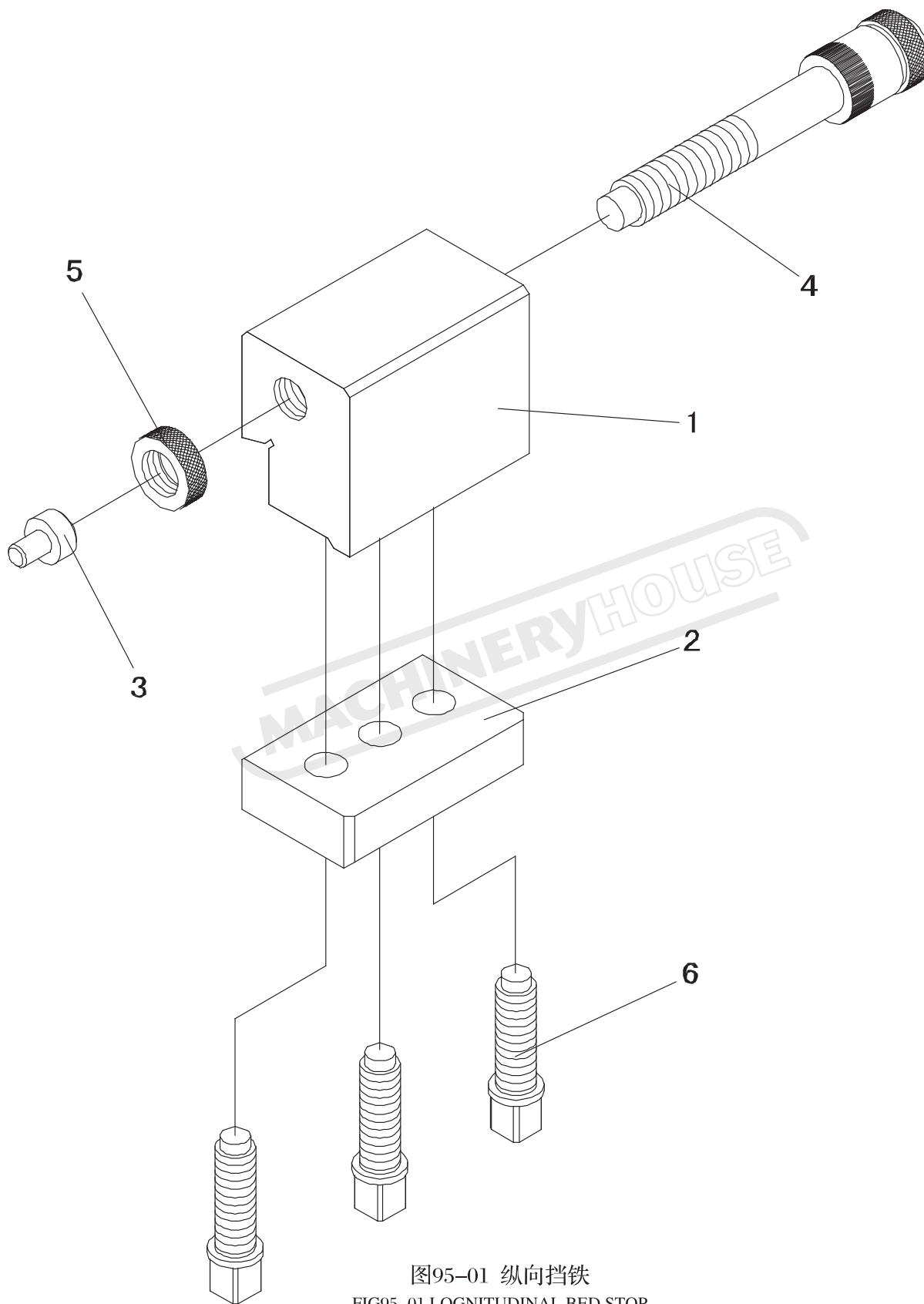
95

95-01

## 纵向挡铁

LOGNITUDINAL BED STOP

图上序号 POSITION No.	件号 PART No.	名称 DESCRIPTION	数量 Q'TY	附注 REMARKS
1	CW6163C-95-011	挡铁体 BLOCK	1	
2	CW6163C-95-012	压板 CLAMPING PLATE	1	
3	CW6163C-95-013	顶销 KNOCK	2	
4	22.1046. 1003-00	挡铁螺栓 BOLT	1	
5	13.1020. 1025-01	滚花螺母 KNURLED NUT	1	
6	GB83	螺钉 SCREW M16X55	3	

MACHINERYHOUSE